

1 - TECHNICAL SPECIFICATIONS

A. GAS NAILER

Model No.	GT60LI-EXIF
Dimensions	
Length	20.67" (525 mm)
Height	13.78" (350 mm)
Width	4.72" (120 mm)
Weight	8.8 lbs (3.99 kg)
Recommended Usage	800/Hr 4,000/Day

Noise

$L_{pA,1s}$	= 97 ± 2dB (A)
$L_{pC,peak}$	= 130 ± 2dB (C)
$L_{pA,1s}$	= 91 ± 2dB (A)
$L_{WA,1s}$	= 104 ± 2dB (A)

Vibration

The vibration/mechanical impact risk is low, it is the users' responsibility to ensure that the operators are not put at risk due to environmental and work piece specifications.

B. FUEL CELL

Model No.	GTFUEL
Dimensions	
Height	152 mm
Capacity	1,000 shots

Fuel cell contains pre-mixed fuel and lubrication. No extra lubrication required.

Warning! Only specified Fuel Cell and Lubricant by Aerosmith Fastening Systems can be used on the tools, please consult the Aerosmith Fastening Systems agents or local distributors.

C. FASTENER

Dimensions	
Insulation Thickness	1"-6" (25-152mm)
Pin Head Ø	.250" (6.3 mm)
Pin Length	1-1/2"-2" (40-52 mm)
Pin Shank Ø	Up to .145" (3.7mm)

Applications

Insulation Thickness 1"-6" (25-152mm)

Only those fasteners which are specified in this specification shall be used in Aerosmith Fastening Systems Gas Tools. The Aerosmith Fastening Systems Gas Tool and the fasteners specified are to be considered as one unit safety system.

The charger and the battery are designed to operate together as one system.

D. CHARGER

Model No.	GTCHR2
Input	100 - 240V~ 50/60Hz 25W Max.
Output	7.2V --- 2.0A
Charging Time	1 Hour
Battery Type	Aerosmith B7220VL

E. BATTERY

Model No.	GTBAT2
Type	Li-ion
Output	7.2V ---
Capacity	2.0Ah/14.4Wh, 2 cells

2 - TOOL SERIAL NUMBER

Located on the tool handle near the track connection.

02 YY MM 85 XXXX

- 02 - Customer Code
- YY - Year of construction (last two digits)
- MM - Month of construction
- 85 - Model Type
- XXXX - Tool serial number

3 - PARTS LIST

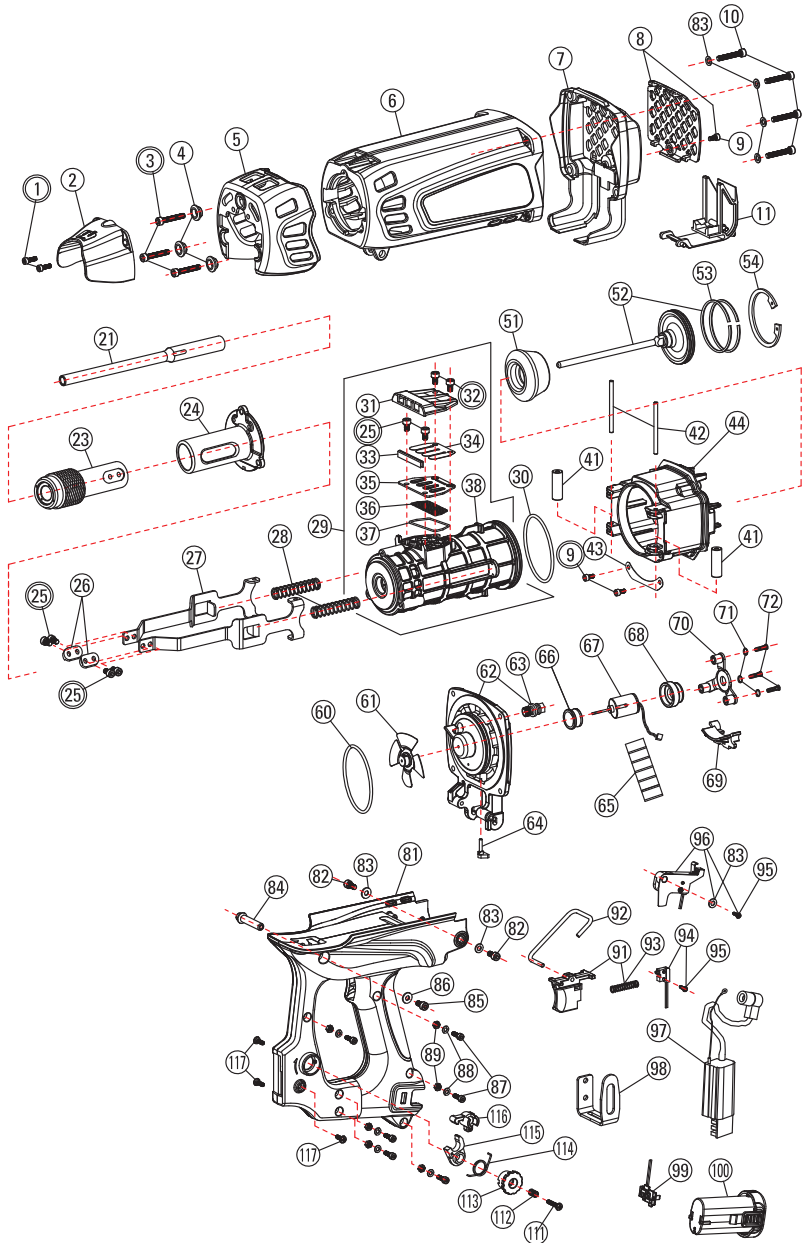

POS.	CODE	DESCRIPTION	POS.	CODE	DESCRIPTION
1	NB1371	SOCKET SCREW	65	NB1670	MOTOR SLEEVE
2	170060	CAP	66	170420	MOTOR BUMPER
3	NB1040	SOCKET SCREW	67	170430	MOTOR
4	NB1050	BUSHING	68	170440	MOTOR GUIDE
5	170090	SHEILD	69	170490	CONNECTOR HOLDER
6	178010	HOUSING	70	170450	MOTOR HOLDER
7	178020	HEAD COVER	71	NB1720	SPRING WASHER
8	178160	FILTER	72	NB1730	ROUND HEAD SCREW
9	NB1160	SOCKET SCREW			
10	172860	SOCKET SCREW	81	178090	HANDLE HOUSING
11	170620	FUEL DOOR	82	172560	SOCKET SCREW
			83	NB1290	WASHER
21	270010	PIN GUIDE	84	178100	BUSHER
23	278040	GUIDE SLEEVE	85	NB110A	SOCKET SCREW
24	270110	NOSEPIECE	86	NB1110	WASHER
25	NB4400	SOCKET SCREW	87	172800	SOCKET SCREW
26	270150	ARM CONNECTOR	88	NB1380	WASHER
27	170160	ARM	89	NB1170	LOCKNUT
28	170260	SPRING			
29	178050	CYLINDER	91	178110	TRIGGER
30	170240	CYLINDER RING	92	170780	CHAMBER STOP
			93	170760	TRIGGER SPRING
31	170230	VALVE COVER	94	178121	TRIGGER SWITCH
32	172141	SOCKET SCREW	95	NB1270	SELF TAP SCREW
33	170180	FILTER	96	178131	MOTOR SWITCH
34	170220	REED	97	170720	CONTROL UNIT
35	170210	VALVE PLATE	98	170830	HOOK
36	170200	PERFRORATED PLATE	99	170710	BATTERY HOLDER
37	170190	SEALING RING	100	171021	BATTERY
38	170170	CYLINDER BODY			
			111	172700	SELF TAP SCREW
41	170310	RUBBER SLEEVE	112	170690	SPRING
42	170320	STEEL PIN	113	170680	KNOB
43	170340	CHAMBER PLATE	114	170670	SPRING
44	178060	CHAMBER	115	170660	TRACK LOCK
			116	170650	TRACK LATCH
51	170250	BUMPER	117	NB1142	SELF TAP SCREW
52	278070	PISTON			
53	170280	PISTON RING			
54	170290	RETAINING RING			
60	170380	HEAD RING			
61	NB1620	BLADE ASSEMBLY			
62	178080	CYLINDER HEAD			
63	NB1650	SPARK PLUG			
64	170480	FUEL NOZZLE			