

Go Beyond Normal Limits...SM



QuickTalkTM Wireless Voice Alarm Reporter Owner's Manual

with Advanced Features Section

- CONSTRUCTION
- FACTORIES
- WAREHOUSES
- FARMS
- UTILITIES
- AIRPORTS
- RETAIL STORES
- SECURITY
- LAW ENFORCEMENT
- SHIPPING
- APARTMENTS
- SPORTS
- HOTELS
- RESTAURANTS
- SCHOOLS
- TRANSPORTATION



Ritron Publication RQT-UM1 14500006 Rev.1 05-04

Copyright©2002-2004 RITRON, INC. — ALL RIGHTS RESERVED
RITRON®, PATRIOT®, JOBCOM®, Quick Assist®, and Quiet Call® are registered trademarks of
RITRON, INC. Quick Talk™ is a trademark of RITRON, INC.

P.O. Box 1998, Carmel, IN 46082-1998 • 505 W. Carmel Dr., Carmel, IN 46032 • USA
PH: 317-846-1201; 800-USA-1-USA (800-872-1-872) • FAX: 317-846-4978
E-mail: ritron@ritron.com

www.ritron.com



TABLE OF CONTENTS

DESCRIPTION	PAGE
WHAT THIS MANUAL COVERS	ii
WARNINGS AND CAUTIONS	ii
ACCESSORIES AND OPTIONS	ii
INTRODUCTION	1
General	1
Model Identification	1
FEATURES	1
Basic Features	1
Advanced Features	1
CONTROLS & CONNECTORS	2
PROGRAMMING	3
STANDARD FEATURES	3
Frequently Asked Questions	3
Testing Your Programming Telephone	3
Transmitter Frequency	4
Quiet Call Coded Squelch Codes	5
Digital Quiet Call Squelch Codes	6
Testing Your Quick Talk	6
Setting Narrow/Wide-band Channels	7
Companded Audio Selector	7
Settings for Battery Type	7
Connecting to an External 12 VDC Power Supply	8
Testing Your Switch	9
Recording Voice Messages	10
Playing Back Voice Messages	10
Programming Voice Phrase Repetitions	11
Programming a Transmission Schedule	11
Limiting the Number of Transmissions	12
Resetting to Factory Defaults	12
Using an External Power Supply	12
Recording a Unique Low Battery Message to Identify a Quick Talk	13
Restarting the Quick Talk when You are Done Programming	13
Connecting to External Power Source	13
ADVANCED FEATURES	14
Programming Non-table Transmitter Frequencies	14
Configure Switch Terminals	14
Adding a Second Switch to Disable the Quick Talk Transmitter	14
Setting Debounce Options	15
Monitoring 4-20 mA Sensor Loops	16
Solar Panels for Operation & Charging	16
Using Latching Option	16
Recording Unique Power Failure Messages	18
Enable/Disable Status Messages	18
Setting Battery Saver Options	18
INSTALLATION	19
Care and Maintenance	19
QUICK REFERENCE GUIDE	20
RITRON WIRELESS SOLUTIONS	22
F.C.C. LICENSING	24
WARRANTY	24
REGISTRATION	Back Cover

ACCESSORIES FOR QUICK TALK

These replacement and optional items are available from Ritron and its authorized dealers.

Item	Description
AFB-1545	Standard 16 in. Flexible Whip Antenna
RAM-1545	Magnetic-Mount Antenna w/ 20 ft. of Cable and a BNC Connector

WHAT THIS MANUAL COVERS

This manual (Ritron Item: RQT-UM1), covers basic operation of the Quick Talk Wireless Voice Alarm Reporter. For most applications, this is all the information you will need. More complex features of Quick Talk are explained in the Advanced Features Section of this manual.

— — — WARNING — — —

IMPORTANT SAFETY INFORMATION

NOTICE: The Quick Talk unit should not be used to report conditions relating to safety of life or property.

To reduce the risk of fire, electric shock or personal injury, follow these basic safety instructions when using this unit.

1. Read and follow all instructions.
2. Disconnect the unit before cleaning. Do not use liquid or aerosol cleaners.
3. Use only approved power sources for the unit.
4. During thunderstorms, avoid contact with this unit and any external antenna system or wiring.
5. The Quick Talk switch and external power terminals are connected internally to the antenna connector. If the Quick Talk switch or power supply terminals contact high voltage, a hazardous condition may exist in that contacting the antenna could prove injurious or even fatal.
6. In general, the switches you connect to the Quick Talk are to be independent dry contact switches, and not part of any other "live" electrical circuit
7. If you are unsure whether your installation will be safe, contact an experienced electrician or electronics technician.

ABOUT THE QUICK TALK™ WIRELESS VOICE ALARM REPORTER

GENERAL INFORMATION

The Quick Talk™ is a wireless radio transmitter that reports changes in the status of switches by transmitting user-recorded voice messages to two-way mobile, portable or base station radios. Quick Talk transmits your voice message when the switch change occurs, and at intervals you select.

Because you provide and connect the switches, your Quick Talk units can report on the status of intrusion, tampering, equipment malfunction, liquid levels, machinery, pressure, temperature, power, smoke or leakage.

The Quick Talk is easily programmed to transmit on either an existing or a new radio frequency, with the most popular sub-audible coded squelch formats, such as Quiet Call® or Digital Quiet Call™. This enables all your personnel with JOBCOM®, PATRIOT®, or equivalent two-way radios to hear the voice messages instantly, and to be advised of the current condition of each monitored location or device.

Quick Talk is housed in a weather-resistant enclosure, so it can be installed in a wide variety of indoor and outdoor locations. Because its six internal AA Alkaline batteries will power the unit for about a year, Quick Talk does not

require AC line power.

QUICK TALK MODELS AND FREQUENCIES

There are two Quick Talk models, one for each of the most popular professional radio communications bands. The model number appears on a label on the front of the case, and on a second label inside the case.

MODEL	BAND	FREQUENCY RANGE
RQT-150	VHF-FM	150 to 165 MHz
RQT-450	UHF-FM	450 to 470 MHz

Ritron manufactures mobile, portable and base station two-way radios and repeaters for use with Quick Talk. Ritron pioneered the use of Color Dots on radios to identify frequencies.

Factory-programmed, default Quick Talk frequencies are:

- Blue Dot = 154.570 MHz for VHF units;
- Blue Star = 467.925 MHz for UHF units.

See page 4 for instructions on changing the Quick Talk transmit frequency to match an existing radio system.

QUICK TALK™ WIRELESS VOICE ALARM REPORTER FEATURES

DESCRIBED IN THE BASIC FEATURES MANUAL:

- Internal radio transmitter (separate VHF and UHF models).
- User-recorded voice messages; total recording time of 16 seconds.
- Terminals for connection to user-supplied switches.
- Included external antenna.
- Typical range of 1/2 mile. Longer range is possible using an optional antenna.
- Weather-resistant (not waterproof nor immersible) enclosure.
- Internal battery holder for six (6) AA Alkaline cells.
- Companded Audio - Selectable.
- External 12 VDC power supply with battery back-up.
- Modulation Select for Narrow/Wide-band Channels
- Connection and use of an external 12 Volt DC power supply.
- Typical operating battery life of 1 year.
- Automatic low battery message.
- Limited One-year Factory Warranty.
- The following programmable features:
 - Transmit Frequency;
 - Tone Coded Squelch Encoder (Quiet Call® Interference Eliminator);
 - Digital Coded Squelch Encoder (Digital Quiet Call™ Interference Eliminator);
 - Message transmission schedules and limits.

DESCRIBED IN THE ADVANCED FEATURES SECTION:

- Use of the second switch input terminals for messages
- Analog voltage (or 4-20 mA loop) inputs
- Multiple location identification messages
- Terminated alarm loop inputs
- Use of solar power panels to operate and charge internal NiCad batteries
- Enabling and disabling the low battery or external power failure messages
- Battery saver options

IDENTIFICATION OF CONTROLS AND CONNECTIONS

1 ANTENNA CONNECTOR

The antenna radiates radio signals. Before using Quick Talk, make sure the antenna is fastened securely to this connector. See page 21.

2 TELEPHONE JACK

The modular telephone jack provides temporary connection to a standard pulse or rotary mode telephone unit, which is used by the owner to program Quick Assist voice messages and other settings.

WARNING: DO NOT connect the Quick Talk to a line from the telephone company; doing so will damage the unit, and void the manufacturer's warranty.

3 BATTERY HOLDER

The battery holder accommodates the six (6) standard "AA" alkaline cells required to power the Quick Talk.

NOTE: ALWAYS INSTALL A FRESH SET of alkaline batteries before programming the unit.

4 SWITCH #1 TERMINALS

These terminals are for connection to a switch the user supplies. Quick Talk transmits voice messages determined by the state of this switch.

5 SWITCH #2 TERMINALS

These terminals are for connection to an optional user-supplied switch. This manual describes how to use Switch #2 as an On/Off switch to enable or disable the Quick Talk transmitter, as well as programming normal debounced and contact closure settings, and latching mode. Refer to page 9 for details.

6 EXTERNAL POWER TERMINALS

Refer to page 8 for information about connecting an external 12 Volt DC power supply to these terminals.

7 WATERTIGHT STRAIN RELIEF CABLE FITTING

The cable to your external switches passes through this fitting. When the strain relief fitting is used with recommended cable sizes, it provides a water-resistant enclosure. Do not overtighten this fitting.

NOTES: Use Radio Shack Telephone Station Wire, 6-conductor, solid 24-AWG In-wall Type CM, Cat. No. 278-874, or equivalent size round cable (0.114 – 0.250" diameter).

If you cannot find suitable wire, call Ritron at 800-872-1872.

8 TRANSMITTER BANDWIDTH SELECT JUMPER

DO NOT remove this jumper. As described on page 7, this jumper controls selection of wide or narrow bandwidth.

9 BATTERY TYPE SELECT JUMPER

DO NOT remove this jumper. As described on page 8, this jumper controls charging of optional Ni-Cd batteries.

10 COMPRESSED/NOT-COMPRESSED AUDIO SELECTOR

Do not remove this jumper. The Quick Talk can be used with two-way radios that use "companded audio." For radios with Companded Audio - place the jumper in the COMP position. For radios without Companded Audio - place the jumper in the NON-COMP position. To determine if your radio uses companded audio, call Ritron or your radio supplier. Refer to page 7.

IMPORTANT: Do not remove any other fasteners or further disassemble the Quick Talk unit; doing so risks damage to the unit and voiding the manufacturer's warranty.

FIG-1: CONTROL & CONNECTION LOCATIONS

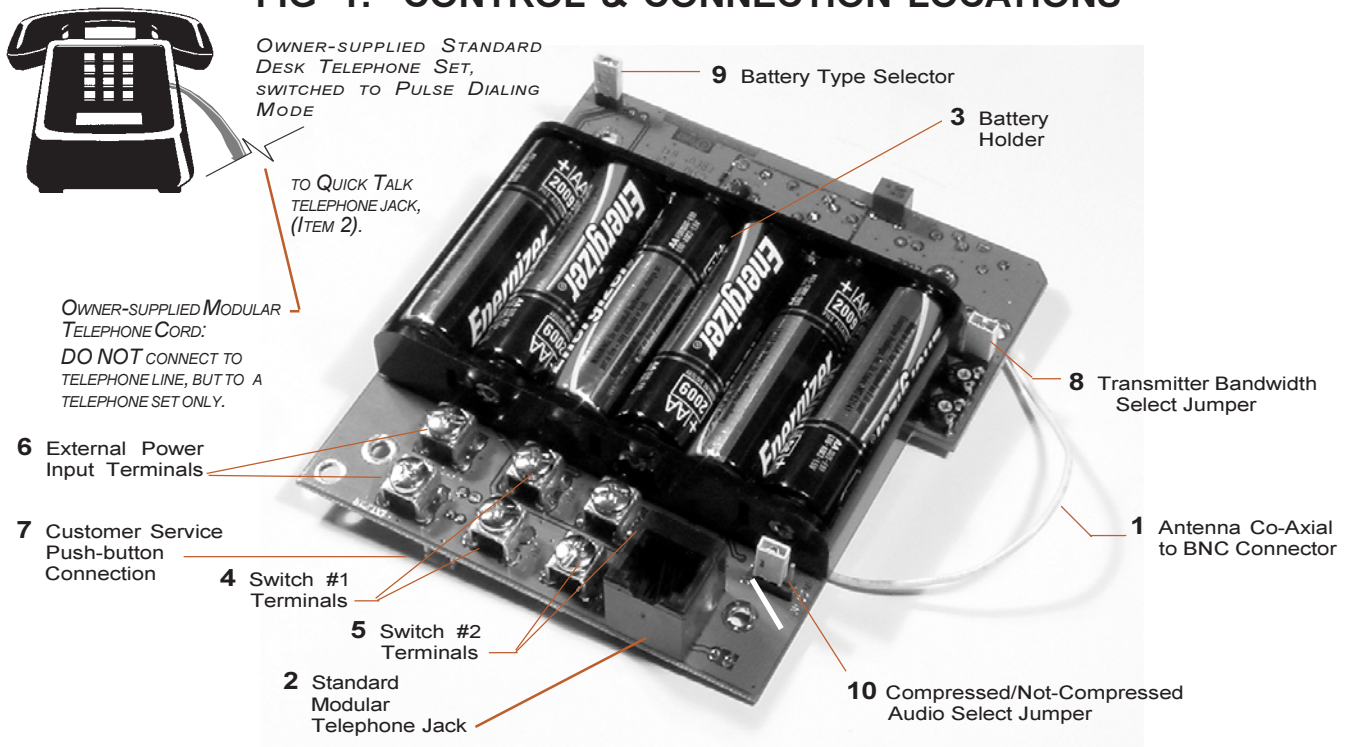

PROGRAMMING YOUR QUICK TALK

FREQUENTLY ASKED QUESTIONS ABOUT QUICK TALK:

Do I have to program my Quick Talk? You may not need to program your Quick Talk at all. If you purchased a Quick Talk that is factory-programmed to your radio system frequency (check the Color Dots on your radios and the Quick Talk), and you do not use a form of Quiet Call coded squelch, you can connect your switch to the terminals marked "Switch #1", install the batteries and start using Quick Talk. The factory default voice messages are "Switch Open" and "Switch Closed". Otherwise, read this manual, then program your Quick Talk.

Do I need to program every feature? In many cases, no. The factory pre-programmed settings, explained in the instructions, may meet many of your needs.

How do I program my Quick Talk? Quick Talk is designed to be programmed using a commonly available standard telephone unit to enter programming information and also to record custom voice messages. However, the telephone must be both capable of and also switched to "Pulse" operation. The telephone is used only for programming; it is to be disconnected when the Quick Talk is operating normally.

What if I don't find what I need in this manual? Call Ritron; we will be glad to help you. For most applications, this manual should cover everything you will need to know. However, the Quick Talk has more capabilities and features than described here. The Advanced Features Owner's Manual, or the Application Notes listed on the inside cover may also be of help. Contact us at Ritron; we can make Quick Talk do just about anything.

Will it harm the Quick Talk if I program it improperly? No; however, you may need to erase all programming and start over; see page 10 to do this. Feel free to experiment with the various features and possible configurations.

Can my settings or messages get lost or erased if the battery runs down, or if my Quick Talk is disconnected? No. The settings and voice messages you enter are stored in special electronic memory devices in the Quick Talk that do not require power to hold the information. This means that if the batteries run down or if you remove them, you will not need to reprogram the unit. All your settings and messages will be there for you when you install fresh batteries.

What if I need more range? To increase the range of your Quick Talk transmissions, we suggest you first **relocate the unit**. Depending on the type of switch and wiring, you may use several hundred feet of wiring to connect the switch — this allows installation of the Quick Talk and its attached antenna for the best range, at an unobstructed and elevated position.

Also, Ritron offers several **optional "high gain" antennas**.

And, Ritron can provide a **radio repeater** to increase the range not only for your Quick Talk, but also for your entire radio system.

TEST THE TELEPHONE YOU WILL USE TO PROGRAM THE QUICK TALK:

A telephone that generates only Touch Tones CANNOT BE USED to program the Quick Talk.

Most special office telephones, speaker phones, and telephones with lighted dials usually cannot be used to program the Quick Talk.

- a. Remove the screws from the Quick Talk, then remove the cover from the unit. Use care to not damage or disturb any exposed internal components.
- b. Install six new alkaline "AA" batteries in the Quick Talk, matching the polarity marks on the batteries with the marks on the battery holder.
- c. Be sure your telephone is capable of "Pulse" mode. Most modern telephones have a selection switch for "P" (Pulse) and "T" (Tone). A "Pulse" mode telephone generates a rapid series of clicks (rather than Touch Tones) with the input (dialing) of each digit. If the telephone has this switch, it must be set to "P" (Pulse) to program the Quick Talk.
- d. The telephone must have a cord with a standard modular plug attached; insert the plug into the telephone jack in the Quick Talk.
- e. Test the telephone for suitability by plugging it into the Quick Talk's telephone jack and dialing "0" (Operator). A repeating busy signal in the telephone earpiece indicates it is acceptable for programming the Quick Talk.

If this telephone does not check out, try another.

Using the Telephone to Program Quick Talk

- Program the Quick Talk by dialing telephone numbers representing commands and settings, as this manual instructs.
- If you make a dialing error while programming, hang up the handset, then pick it up and dial again.

What the Tones (Beeps) in the Telephone Receiver Mean

- Quick Talk sounds a **brief acknowledgment tone** when you pick up the telephone handset; wait to hear this tone before you dial.
- Quick Talk emits a **series of repeating tones** until you hang up, if you mis-dial or if you use an invalid command; you may then pick up the handset and try your command again.
- Quick Talk responds with a **confirmation tone** after you dial command and setting numbers; you may then either hang up or dial another command.
- A series of **three short tones** cues you to begin speaking when you dial the command for recording a voice message into Quick Talk.

PROGRAMMING YOUR QUICK TALK TRANSMITTER FREQUENCY

What is my Radio System Frequency? Ritron pioneered the Color Dot system to simplify the identification of radio system frequencies for Ritron Jobcom radios. Color Dots are placed on the bottoms of and inside the enclosures of all Jobcom radios. Other manufacturers have also adopted this idea.

To identify your assigned frequency if your radios do not have a color dot, locate a label identifying the receiver frequency in megahertz (MHz). Your assigned frequency is also shown on your F.C.C. Station License. Call your radio dealer or Ritron for help if you cannot determine your radio's receiver frequency.

Do I need to program my Quick Talk's transmitter frequency? The original factory-programmed transmitter frequency of your Quick Talk is marked on the outside of the shipping box, and is also indicated by a color dot on the inside the unit case. If the Quick Talk frequency matches your radio system frequency, and if the Quick Talk has not been reprogrammed since it left the factory, you may skip this section and proceed to the next.

Note: To program a **non-table** frequency refer to page 14.

TO PROGRAM THE QUICK TALK TRANSMITTER FREQUENCY:

- Determine the frequency of your radio system.
- Find your frequency in the appropriate table at right, and determine its corresponding two digit code. If your radio system frequency is not in the chart, your Quick Talk must be programmed by a radio dealer or by Ritron.
- Pick up the telephone receiver, and listen for the acknowledge tone. Dial "11", then the digits of the selected frequency code from the table.

Examples: If the Quick Talk is a VHF RQT-150 model, and the radios operate on 154.570 MHz (Blue Dot frequency), dial "11-02".

If the Quick Talk is a UHF RQT-450 model, and the radios operate on 467.925 MHz (Blue Star frequency), dial "11-08".

- Quick Talk responds with a single beep to indicate it has programmed the transmitter frequency.
- You may either hang up or continue programming.

NOTES: If you make a dialing mistake while programming, hang up the telephone handset, then pick it up and dial again.

If you reprogrammed the Quick Talk frequency, you may wish to remove the Color Dot from inside the case, to avoid later confusion.

What the Tones (Beeps) in Your Earpiece Mean:

- A series of **three short tones** cues you to begin recording a message.
- A **single brief tone** means your command is accepted and stored.
- A series of **long repeating tones** means your command was not understood; hang up and dial again.

TABLE 1: TRANSMIT FREQUENCY CODES

(VHF Business Band)

QUICK TALK FREQ. CODE	Model RQT-150	
	MHz	Frequency Color
01	154.600	Green Dot
02	154.570	Blue Dot
03	151.625	Red Dot
04	151.955	Purple Dot
05	151.925	
06	154.540	
07	154.515	
08	154.655	
09	151.685	
10	151.715	
11	151.775	
12	151.805	
13	151.835	
14	151.895	
15	154.490	
16	151.655	
17	151.745	
18	151.865	

(UHF Business Band)

QUICK TALK FREQ. CODE	Model RQT-450	
	MHz	Frequency Color
01	467.7625	J
02	467.8125	K
03	464.5500	Yellow Dot
04	464.5000	Brown Dot
05	467.8500	Silver Star
06	467.8750	Gold Star
07	467.9000	Red Star
08	467.9250	Blue Star
09	469.2625	
10	462.5750	White Dot
11	462.6250	Black Dot
12	462.6750	Orange Dot
13	464.3250	
14	464.8250	
15	469.5000	
16	469.5500	
17	463.2625	
18	464.9125	
19	464.6000	
20	464.7000	

PROGRAMMING THE QUIET CALL SUB-AUDIBLE CODED SQUELCH INTERFERENCE ELIMINATOR

What is Quiet Call Sub Audible Coded Squelch?

The Quick Talk radio transmitter is compatible with two standard communications industry sub-audible signaling formats: QC® (Quiet Call Interference Eliminator), and DQC™ (Digital Quiet Call Interference Eliminator). Both Quiet Call formats unlock receivers programmed to require these codes -- they screen out interference from other radio systems operating on your same frequency.

QC® Quiet Call is Ritron's trade name for what the communications industry calls sub-audible (below the range of human hearing) tone squelch, or CTCSS (Continuous Tone Coded Subaudible Squelch). Other radio manufacturers use different trade-names for essentially the same system. You may program a specific QC code into your Quick Talk to transmit with the voice messages, which will "unlock" the receivers in your radio system.

DQC™ Digital Quiet Call is Ritron's digital coded squelch, and works the same as QC, except it is a **digital** code that is transmitted with the voice messages.

Do I need to program my Quick Talk with a Quiet Call Code? Your radio system may or may not use coded squelch signaling. If you have programmed the Quick Talk to match your radio frequency, and your radios are not receiving Quick Talk transmissions unless the "monitor" or "test" button is pressed, your system is probably using Coded Squelch. Refer to your radio manual, or contact your radio dealer or Ritron if you are unsure about this issue.

If your Quick Talk was previously programmed with a Quiet Call code and you need to remove it, follow the procedure below, using No Tone code, "44", as shown in the table.

To Program A Quiet Call Sub-Audible Squelch Code:

- a. Determine the Quiet Call code tone that your radio system uses. If your system uses Digital Quiet Call, go to the next page.
- b. Select the desired Tone Code from Table 2 at right; write down the code.

NOTE: If your radio system does not use coded squelch, program **No Tone**, code, "44".

- c. Pick up the telephone receiver and listen for the acknowledge tone.
- d. Dial "21", then the 2-digit QC Code you have selected.

For example, if your Quiet Call frequency is 103.5 Hz (Code 13), dial: "21-13".

Quick Talk will respond with a confirmation tone.

- e. You may either hang up or continue programming additional features.

TABLE 2: QUIET CALL TONE CODES

QUICK TALK QC CODE	Freq. (Hz)	Other Radio Brands Tone Code	QUICK TALK QC CODE	Freq. (Hz)	Other Radio Brands Tone Code
01	67.0	XZ	27	167.9	6Z
02	71.9	XA	28	173.8	6A
03	74.4	WA	29	179.9	6B
04	77.0	XB	30	186.2	7Z
05	79.7	SP	31	192.8	7A
06	82.5	YZ	32	203.5	M1
07	85.4	YA	33	210.7	--
08	88.5	YB	34	218.1	--
09	91.5	ZZ	35	225.7	--
10	94.8	ZA	36	233.6	--
11	97.4	ZB	37	241.8	--
12	100.0	1Z	38	250.3	--
13	103.5	1A	39	69.4	--
14	107.2	1B	40	159.8	--
15	110.9	2Z	41	165.5	--
16	114.8	2A	42	171.3	--
17	118.8	2B	43	177.3	--
18	123.0	3Z	*44	No Tone	--
19	127.3	3A	45	183.5	--
20	131.8	3B	46	189.9	--
21	136.5	4Z	47	196.6	--
22	141.3	4A	48	199.5	--
23	146.2	4B	49	206.5	--
24	151.4	5Z	50	229.1	--
25	156.7	5A	51	254.1	--
26	162.2	5B			

* Use Code "44" to program No Tone for systems without a Coded Squelch Interference Eliminator feature. Refer to the text at left.

WRITE DOWN your frequency (from page 4), and your QC code (from page 5 or page 6).

Frequency: _____ ; QC code: _____

PROGRAMMING DIGITAL QUIET CALL SUB-AUDIBLE CODED SQUELCH INTERFERENCE ELIMINATOR

What is Digital Quiet Call? Digital Quiet Call (DQC) is a digital sub-audible coded squelch system.

Do I need to program my Quick Talk with a Digital Quiet Call code? If your radio system does not use Digital Quiet Call, or any other tradename equivalent, skip this section and go to the next programming feature.

TO PROGRAM A DIGITAL QUIET CALL CODE:

- a. Determine the specific Digital Quiet Call (DQC) code used for your system, then make sure this code is listed in Table 3, which shows all of the possible DQC codes for Quick Talk. If your system code is not listed, call your radio service provider or Ritron.
- b. Write down your code.
- c. Pick up the telephone receiver, and listen for the acknowledge tone.
- d. Dial "22" followed by the selected 3-digit DQC code. For example if your DQC code is "131", dial "22-131".
Wait for the Quick Talk Confirmation Beep.
- e. You may either hang up or continue programming.

TABLE 3: DIGITAL QUIET CALL CODES

Normal	Invert	Normal	Invert	Normal	Invert
023	047	174	074	445	043
025	244	205	263	464	026
026	464	223	134	465	331
031	627	226	411	466	662
032	051	243	351	503	162
043	445	244	025	506	073
047	023	245	072	516	432
051	032	251	165	532	343
054	413	261	732	546	132
065	271	263	205	565	103
071	306	265	156	606	631
072	245	271	065	612	346
073	506	306	071	624	632
074	174	311	664	627	031
114	712	315	423	631	606
115	152	331	465	632	624
116	754	343	532	654	743
125	365	346	612	662	466
131	364	351	243	664	311
132	546	364	131	703	565
134	223	365	125	712	114
143	412	371	734	723	431
152	115	411	226	731	155
155	731	412	143	732	261
156	265	413	054	734	371
162	503	423	315	743	654
165	251	431	723	754	116
172	036	432	516		

TEST YOUR QUICK TALK WIRELESS VOICE ALARM REPORTER

What is the purpose of testing the Quick Talk radio transmitter?

After following the previous instructions, your Quick Talk will be programmed to transmit on the same frequency as your radio receivers, and you also will have programmed your Quick Talk to transmit any coded squelch signals required for your radio system.

Do I need to test my Quick Talk Transmitter? Yes; performing this test now will save you time and confusion later.

TO TEST THE QUICK TALK RADIO TRANSMITTER:

- a. Attach the Quick Talk flexible antenna.
- b. Turn on your radio receiver.
- c. Momentarily place a screwdriver, paper clip or other electrically conductive item across the Switch #1 terminals.
- d. Quick Talk transmits the Closed and Open Switch messages, which you should be able to hear on your radio receiver.

If you do not hear the messages, you have probably not properly programmed the Quick Talk transmitter frequency or the Quiet Call Coded Squelch. In this case, repeat the programming, then perform this test again.

SETTING NARROW OR WIDE-BAND CHANNELS

Determine the frequency of your radios. This can be done by checking with your radio dealer, or if you are using "Color Dot" radios, match the color dot to the frequency table on Page 2. As a general rule, if your frequency has three or less numbers past the decimal point, your radio is set for wideband. Example 154.570 MHz, 462.625 MHz. If your frequency has more than three numbers past the decimal point, it is probably set for narrowband. Example: 467.7625 MHz, 467.8125.

Wide: (Refer to FIG-2)

To set your **Quick Talk** into wideband position, place the Transmitter Bandwidth Select Jumper so that both pins of the 2 pin connector are covered by the jumper.

Narrow: (Refer to FIG-2)

To set your **Quick Talk** into narrowband position, place the Transmitter Bandwidth Select Jumper so that only 1 pin of the 2 pin connector is covered by the jumper.

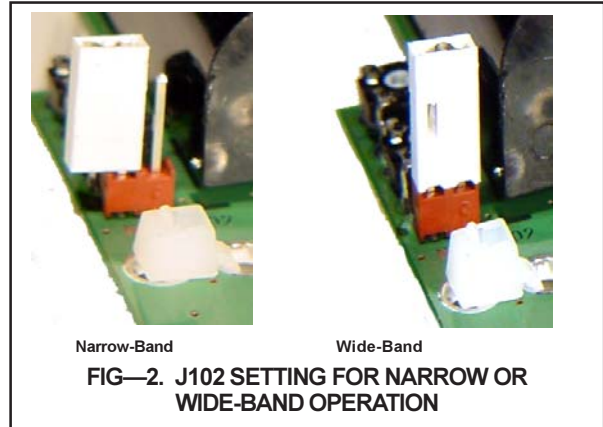

COMPRESSED/NOT-COMPRESSED AUDIO SELECTOR JUMPER

Some two-way radios have a feature referred to as "companding". It is a way of eliminating background "hiss" or noise, making the radio sound clearer. "Companding" is a combination of audio "COMPression" in the transmitter and audio "exPANDing" in the receiver. The **Quick Talk** can be set for audio compression by means of a program jumper. To determine if your existing 2-way radios are using the Companding feature, you can check the radio's User Manual, contact your radio dealer, or call Ritron for help.

Not-Compressed: (Refer to FIG-3)

To set the **Quick Talk** for standard audio or not-compressed, place the jumper so that the middle pin and the pin closest to the word "NON-COMP" are covered by the jumper.

Compressed: (Refer to FIG-3)

To set the **Talk** for compressed audio, place the jumper so that the middle pin and the pin closest to the word "COMP" are covered by the jumper.

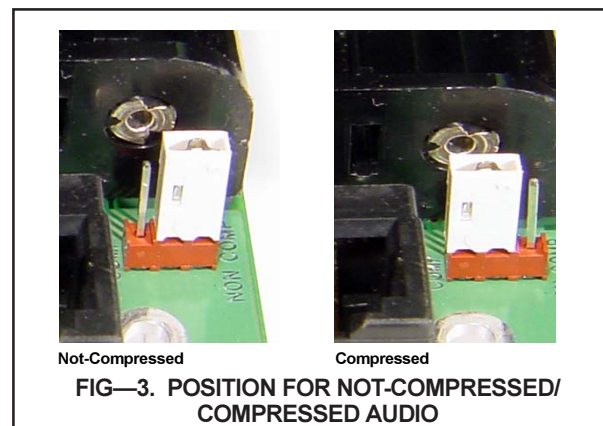

IMPORTANT

You may change the Transmitter Bandwidth and Compressed/Non-Compressed Audio jumper settings without re-recording your custom voice message.

If you are unable to determine if your portable radio uses the companding feature, we suggest the following:

1. Leave the jumper in the factory default setting **NON-COMP**.
2. Activate the transmitter of the Quick Talk or Quick Assist (I or II) and listen to the message from your portable radio. If the received audio is acceptable, skip the rest of this section, if it's not acceptable continue to step #3.
3. Change the jumper setting to the **COMP** position and activate the Quick Talk or Quick Assist (I or II) transmitter again, and listen to the voice message.

Place the jumper in the setting that produces the best "received" audio message in the radio you will be using.

J103 JUMPER SETTINGS FOR BATTERY TYPE

NOTE: When programming, use either fresh Alkaline batteries (or an external power supply), to power the Quick Talk. When programming is finished, you may either insert Ni-Cd batteries or leave Alkaline batteries in place.

WARNING: DO NOT attempt to charge Alkaline batteries from an external +12 VDC power supply.

When powering Quick Talk with **ALKALINE BATTERIES**, set J103 as follows to disconnect the charging current paths:

- a. To set the Quick Talk for use with alkaline batteries, move Jumper J103 to cover only one pin of the jumper base, as shown in FIG-4; this setting prevents the flow of charging current.
- b. Dial "943" to program the Quick Talk for use with alkaline batteries.

When powering Quick Talk with **NI-CD BATTERIES**, set J103 as follows to connect the charging current paths:

- c. Cover both pins with Jumper J103, as shown in FIG-4, to charge the Ni-Cd batteries from the External Power connection.
- d. Dial "944" to adjust the Quick Talk voltage; the unit then transmits a "Low Battery" phrase.

NOTE: Because Ni-Cd batteries self-discharge rapidly, you must constantly charge them with an external +12 VDC power.

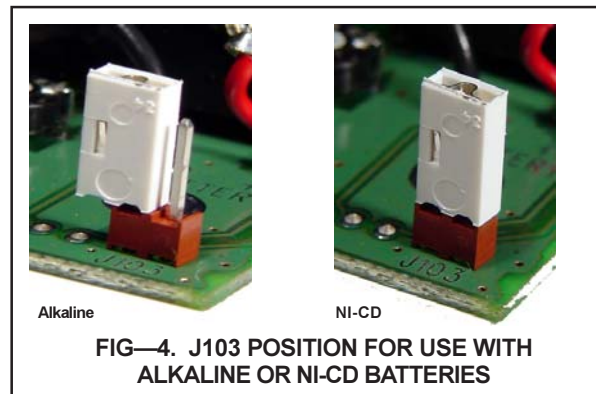

CONNECTING AN EXTERNAL 12 VDC POWER SUPPLY

TO CONNECT AN EXTERNAL 12VDC POWER SUPPLY:

The standard Quick Talk may be used with an external 12 VDC power supply.

Instructions:

1. Route the power supply cable through the Ritron #02500127 strain relief fitting as described in FIG-7 on page 14.
2. Use Ritron #RPS-203 Power Supply (11-15 VDC, 200 mA), or equivalent, to power the Quick Talk. The Quick Talk requires 11-15 VDC, 150 mA minimum.
3. Connect the positive (+) terminal of the power supply cable to the +EXT. PWR screw terminal on the Quick Talk, refer to FIG-5.
4. Connect the negative (-) terminal of the power supply cable to the -EXT. PWR screw terminal on the Quick Talk, refer to FIG-5.

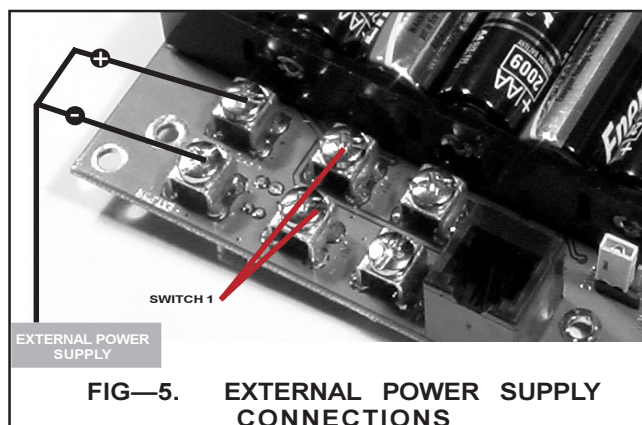

TEST YOUR SWITCH'S OPEN AND CLOSED CONDITIONS

What is the purpose of testing my switch? In Quick Talk's basic operating mode, you may record two (2) voice messages for the Quick Talk to transmit. One message is transmitted when the switch is Opened and the other is transmitted when the switch is Closed. Each message must be eight (8) seconds or less in length.

Before you record these switch condition messages, determine how your switch works by using the factory prerecorded messages in the Quick Talk. After you have programmed the Quick Talk with your radio system frequency and with any required sub-audible squelch codes, use the following procedure.

Do I need to test my switch? If you are certain of the conditions which cause your switch to open and close, you do not need to perform this test. However, we recommend you do test your switch, because doing so will confirm you have properly programmed the Quick Talk transmitter frequency — and, if required for your radio system, the Quiet Call Interference Eliminator squelch code.

To Test Your Switch and Verify Reception of Messages by Your Radios

1. Remove the batteries from the holder.
2. **Review the safety precautions on Page ii of this manual before connecting your switches. When you are sure your connections will be safe, connect your switch to the Quick Talk terminals labeled Switch #1. See FIG-6 below.**
3. Reinstall fresh AA Alkaline batteries in the Quick

Talk according to the polarity marks.

4. Activate your switch; listen to your two-way radio as the factory default messages are transmitted. (The message will be either "Switch One Open" or "Switch One Closed".)

Write down a description of how the condition of your switch corresponds to the transmitted message. Then deactivate the switch and listen to the other transmitted message; again, write down the results.

5. From performing Step 4, above, you should understand how your switch works, and the meaning of its open and closed states — essential knowledge to program a descriptive voice message for each switch condition.

For example, if your switch is a magnetic reed switch on a door, and the switch closes when the door is opened, you can record the phrase "Door three open" for the switch closed condition, and then "Door three closed" for the switch open condition. Note that magnetic reed switches are available which work in the opposite way.

NOTE: We suggest that you **do not record over** the factory prerecorded messages until you are sure how your switch works. If the factory-programmed messages have been erased, you will have to use an electrician's continuity tester or similar instrument to determine how your switch works.

FIGURE 6: CONNECTIONS FOR TESTING YOUR SWITCH

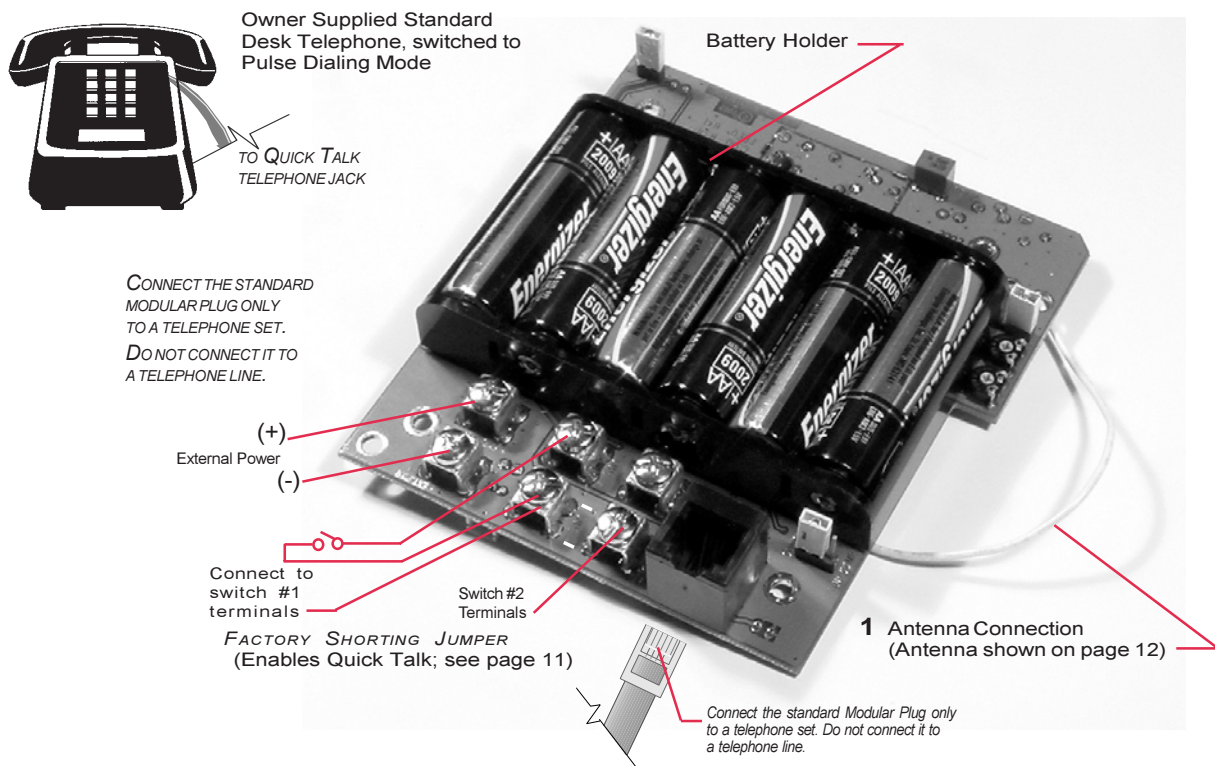

RECORDING VOICE PHRASES FOR YOUR SWITCH CONDITIONS

What is the purpose of Recording Voice Phrases?

Recording customized voice phrases gives Quick Talk messages unmistakable meaning and significance. The standard factory prerecorded messages of "Switch Open" and "Switch Closed" require the listener to know how the switch works and what it does. However, when a user hears a custom message such as "Water pump three running hot", the meaning is clear.

Do I need to program Voice Phrases? If the factory-recorded messages "Switch Open" and "Switch Closed" suit your application, you may skip this section.

Your recorded voice message will sound only as good as the telephone set you use. If your message has the audio too low, record it again, speaking louder. If your message is distorted, record it again, speaking softer. If you are dissatisfied with the audio quality, try a different telephone set.

When the Quick Talk is transmitting, it draws maximum power from the battery, and can also interfere with other transmissions. Therefore, when you record a voice phrase, hang up when you are finished speaking. Otherwise, the Quick Talk transmitter will be on for the full eight seconds, regardless of the actual message length.

To Record Your Switch Open Condition Phrase

- a. Pick up the telephone receiver, wait for the beep and dial "311".
Quick Talk sounds three short tones to prompt you to begin speaking . . .
- b. Record a phrase no longer than eight seconds, describing the open condition of your switch.
Example: "Pump motor temperature OK".
- c. Hang up the telephone when you complete your phrase.
- d. Pick up the telephone and dial "411". Your phrase will be played back through the telephone receiver.
- e. Return to Step a above and record again if you are not pleased with the results.

To Record Your Switch CLOSED Condition Phrase

- a. Pick up the telephone receiver, wait for the beep and dial "312".
Quick Talk sounds three tones to prompt you to begin speaking . . .
- b. Record a phrase no longer than eight seconds, describing the closed condition of your switch.
Example: "Pump motor over temperature".
- c. Hang up the telephone when you complete your phrase.
- d. Pick up the telephone and dial "412". Your phrase will be played back through the telephone receiver.
- e. Return to Step a above and record again if you are not pleased with the results.

PLAYING BACK THE OPEN AND CLOSED VOICE PHRASES FOR YOUR SWITCH CONDITIONS

To Play Back the Switch Open Condition Phrase

- a. Pick up the telephone.
- b. After the tone, dial "411". Quick Talk plays the Switch Open condition phrase.
Example: "Pump motor temperature OK".
- c. Wait for the confirmation beep, then hang up the telephone, or continue programming.

To Play Back the Switch Closed Condition Phrase

- a. Pick up the telephone.
- b. After the tone, dial "412". Quick Talk plays the Switch Closed condition phrase.
Example: "Pump motor running hot".
- c. Wait for the confirmation beep, then hang up the telephone, or continue programming.

PROGRAMMING HOW MANY TIMES YOUR RECORDED VOICE PHRASES ARE REPEATED IN EACH TRANSMISSION

What is the purpose of setting the number of times the Voice Phrase is repeated in each Transmission? Your previously recorded voice phrase can be programmed to repeat from one time to nine times in each Quick Talk radio transmission, depending on how you program this feature. More urgent messages may have more phrase repeats.

Example: You previously recorded the message "Pump Motor Hot", then programmed Quick Talk to repeat the phrase two (2) times in each transmission. In this case, activating the switch results in the Quick Talk transmitting:

"...beep. Pump motor hot. Pump motor hot. beep..."

The beginning and ending beeps are added automatically to attract attention to Quick Talk transmissions.

Do I need to program this feature? The Quick Talk is set at the factory to play each recorded voice phrase one time in each transmission. If this is sufficient for your application, you can skip to the next section, in which we explain how to program the transmission itself to be repeated at different intervals.

To Program the Number of Times the Switch Open Phrase is Repeated in Each Transmission:

1. Pick up the telephone receiver; listen for the tone.
2. Dial "711" then a single digit indicating how many times you want the voice phrase repeated in each transmission, as shown in Table 4.

Example: To repeat the phrase three times, dial "711-3".

Wait for the confirmation tone after dialing.

3. Hang up the telephone or continue programming.

To Program the Number of Times the Switch Closed Phrase is Repeated in Each Transmission:

1. Pick up the telephone receiver, listen for the tone.
2. Dial "712", then a single digit indicating how many times you want the voice phrase repeated in each transmission, as shown in Table 4.

Example: To repeat the phrase five times, dial "712-5".

Wait for the confirmation tone after dialing.

3. Hang up the telephone or continue programming.

— TABLE 4 —

VOICE PHRASE REPEATS IN EACH TRANSMISSION	CODE NUMBER
1 time	1 — DEFAULT
2 times	2
3 times	3
4 times	4
5 times	5
6 times	6
7 times	7
8 times	8
9 times	9

PROGRAMMING A BROADCAST SCHEDULE FOR SWITCH STATUS TRANSMISSIONS

What is the purpose of programming a Broadcast Schedule for Switch Status Transmissions? You can program different switch status transmission schedules for the open condition, and for the closed condition of your switch.

Example: The switch status message for **switch open** is "Pump motor temperature OK". You may schedule the Quick Talk to transmit this message once every two hours; this way, you know the Quick Talk is operating properly.

If the corresponding switch status message for **switch closed** is "Pump Motor Over Temperature", you may schedule the Quick Talk to broadcast this message every two minutes, so the situation would receive prompt attention.

Do I need to program this feature? The Quick Talk is set at the factory to transmit a switch status message one time with each switch change. If this is sufficient for your application, you can skip to the next section.

To Program a Broadcast Schedule of Switch Status Transmissions for the Switch Open Condition:

1. Pick up the telephone receiver; listen for the tone.
2. Dial "511", then dial the one-digit code number from Table 5 below.

The Factory Default is "511-1", which means the transmission is sent one time when the switch changes to open condition.

Wait for the confirmation beep after dialing.

3. Hang up the telephone or continue programming.

To Program a Broadcast Schedule of Switch Status Transmissions for the Switch Closed Condition:

1. Pick up the telephone receiver; listen for the tone.
2. Dial "512", then the one-digit code number from Table 5.

The Factory Default is "512-1", which means the transmission is sent one time when the switch changes to closed condition.

Wait for the confirmation beep after dialing.

3. Hang up the telephone or continue programming.

— TABLE 5 —

MESSAGE SCHEDULE	CODE NUMBER
Never send messages for this condition	0
On switch condition change only	1 — DEFAULT
Every 30 seconds	2
Every (1) minute	3
Every (2) minutes	4
Every (5) minutes	5
Every (10) minutes	6
Every (30) minutes	7
Every (1) hour	8
Every (2) hours	9

PROGRAMMING A LIMIT TO THE NUMBER OF SCHEDULED TRANSMISSIONS

What is the purpose of limiting the number of times a scheduled voice message is transmitted? In the previous section, you have programmed the Quick Talk to transmit a switch status message at regular intervals. In this section, you can set a limit to the number of times the message will be transmitted at the scheduled intervals.

Example: Suppose you have a vehicle detector switch that closes when it detects a vehicle at the delivery door of your building. Your recorded message might then be "Vehicle at Delivery Door". You may want this message to be transmitted every two minutes for approximately a quarter hour after a vehicle is detected, then to stop transmitting until the vehicle is moved. In this case, you would program the message schedule (in the previous section of this manual), for every two minutes, and set the message limit to "8", as described here.

When a vehicle arrives, the switch closes and the message is transmitted every 2 minutes until it has been sent 8 times over a span of 16 minutes, unless the vehicle leaves before 16 minutes has lapsed. In this case, the switch opens and the message ceases when the vehicle is moved.

When another vehicle arrives, the Quick Talk again transmits the message every two minutes for about a quarter of an hour, or until the vehicle leaves.

Do I need to program this feature? The Quick Talk is set at the factory to transmit switch status messages without limit. For example, if you programmed the Quick Talk to transmit a status message every hour, it would continue to do so until the battery runs down. If this programming is sufficient for your application, you can skip to the next section.

Set Scheduled Message Repeat Limit for Switch Open

- From Table 6 below, select the code number for the desired number of messages.
- Lift the telephone receiver and dial "611", then dial the selected Code Number.
Quick Talk responds with the single confirmation tone.
- You may either hang up or continue programming.

Set Scheduled Message Repeat Limit for Switch Closed

- From Table 6 below, select the code number for the desired number of messages.
- Lift the telephone receiver and dial "612", then dial the selected Code Number.
Quick Talk responds with the single confirmation tone.
- You may either hang up or continue programming.

— TABLE 6 —

MESSAGESCHEDULED REPEAT LIMIT	CODE NUMBER
1 time	1
2 times	2
3 times	3
4 times	4
5 times	5
6 times	6
7 times	7
8 times	8
Repeat Forever, No Limit	9 — DEFAULT

TO ERASE AND REPROGRAM THE QUICK TALK TO ORIGINAL FACTORY SETTINGS

What is the purpose of erasing and reprogramming the Quick Talk to its original factory settings? You can erase all your programming to return Quick Talk to its Factory Default Settings with this command.

NOTE: This command does not restore the Factory Default recorded voice messages. Any recorded messages may be lost by use of this command; you will have to record them again, using the instructions in this manual.

Do I need to use this feature? If you are unsure how the Quick Talk features are programmed, and want to start over again, use this feature.

To Erase and Reprogram the Quick Talk Settings as Originally Factory Programmed:

- Pick up the telephone receiver, wait for the acknowledgment tone.
- If your Quick Talk is a VHF-FM RQT-150 model, dial "978", **OR**
If your Quick Talk is a UHF-FM RQT-450 model, dial "979".
- After you hear the confirmation tone, hang up the telephone.
- Play back your voice phrases and re-record them as necessary.

USING AN EXTERNAL POWER SUPPLY

If an external 12VDC power supply is used, route the power supply cable through the strain relief fitting. Refer to FIG-8 on Page 13.

Connect the positive(+) terminal of the power supply cable to the **+EXT. PWR** screw terminal on the Quick Talk (refer to Page 8 for location).

Connect the negative(-) terminal of the power supply cable to the **-EXT. PWR** screw terminal on the Quick Talk (refer to Page 8 for location).

RECORDING A UNIQUE LOW BATTERY MESSAGE TO IDENTIFY A QUICK TALK

What is the purpose of recording a unique Voice Phrase for the Low Battery Message? When it senses the installed batteries are nearly run down, Quick Talk will transmit one time each hour the factory-programmed message: "Low Battery". If you maintain several Quick Talk transmitters within radio range of each other, you may customize this feature to easily determine which unit needs new batteries.

Do I need to program this feature? If you use only one Quick Talk in any area, or if you regularly change Quick Talk batteries, the factory-programmed message may be sufficient for your application. You can skip to the next section.

To Program the Low Battery Alert Phrase:

- a. Pick up the telephone receiver, wait for the beep, then dial "35".
Quick Talk sounds three short tones to prompt you to begin speaking . . .
- b. Record a phrase no longer than one and one-half (1.5) seconds, indicating Low Battery, and identifying the Quick Talk unit.
For example say: "Low Battery Five".
- c. Hang up the telephone when you are done speaking.
- d. Pick up the telephone and dial "45" to hear your phrase played back through the telephone receiver.
- e. If you are not pleased with the results, you may return to Step a above and record again.

NOTE: We suggest you physically mark the Quick Talk with the same unique identifier (number) you recorded.

RESTART THE QUICK TALK WHEN YOU ARE DONE PROGRAMMING

What is the purpose of restarting the Quick Talk? If you have changed message schedules or limits, restarting the Quick Talk ensures that all of internal clocks and counters are set properly.

Do I need to restart the Quick Talk? It is best if you do.

To Leave Telephone Programming Mode and Restart the Quick Talk:

- Pick up the telephone receiver, wait for the beep and dial "999".
Quick Talk responds with a single short tone.

NOTE: Be certain to hang up and to disconnect the telephone from Quick Talk.

1. PROGRAMMING NON-TABLE TRANSMITTER FREQUENCIES

TO PROGRAM A FREQUENCY THAT IS NOT LISTED IN TABLE 1 ON PAGE 4.

1. Review the basic information in the manual.
2. Connect the telephone as shown.
3. Install six (6) new "AA" alkaline batteries as shown
4. Lift the telephone receiver and listen for the acknowledgement beep.
5. Dial "12" followed by the first six (6) digits of the desired frequency. DO NOT dial the seventh (7th) digit of a narrow bandwidth (12.5 kHz) frequency. The Quick Talk will respond with a confirmation tone.
6. Hang up the telephone if you make a mistake, and start over.
7. When you are finished programming, test the unit as described on page 6.

2. CONFIGURE SWITCH TERMINALS

ONE SWITCH INPUT TERMINAL:

- a. Pick up the telephone receiver and listen for the acknowledge tone.
- b. Dial "911". Quick Talk responds with a confirmation tone.

TWO SWITCH INPUT TERMINALS:

- a. Pick up the telephone receiver and listen for the acknowledge tone.
- b. Dial "912". Quick Talk responds with a confirmation tone.

NOTE: If you change from one input terminal to two, or from two input terminals to one, record all new messages. The way messages are stored and the time available for each message differs between the two modes.

3. ADDING A SECOND SWITCH TO DISABLE THE QUICK TALK TRANSMITTER

What is the purpose adding a second switch to disable the Quick Talk? There may be times you want the Quick Talk to **not transmit messages**.

For example, if Quick Talk reports the status of an entry door for the night shift, you may wish to not hear status messages all day. Use the second switch to enable the Quick Talk at night, and disable it during the day.

Add a second switch to disable Quick Talk Messaging:

- a. Remove the shorting jumper from the Switch #2 terminals.
- b. Connect an external switch to the terminals marked Switch #2.

NOTES: Switch #2 in On/ OFF mode, as described here, is a feature of Switch #1 operation. Dial "911" to put Quick Talk into this mode.

When Switch #2 is closed, Quick Talk functions normally. When Switch #2 is open, Quick Talk is disabled and will not transmit messages.

When Switch #2 has been open (Quick Talk disabled), and it is then closed, Quick Talk transmits the prerecorded message describing the current condition of Switch #1.

If you do not need to add a second switch, see the next section.

4. SETTING DEBOUNCE OPTIONS

There are two modes of contact debounce;

1. Normal Debounce, and **2. Holdoff Debounce**:

- 1. NORMAL DEBOUNCE** is an option specifying that the switch must remain in its changed condition for a user-specified time period ("debounce"), before generating a message for the changed condition.

EXAMPLE: A sensor is used to detect a car in a "No Parking" zone. Since it is undesirable for a message to be generated by normal traffic through the "No Parking" zone, a five-minute Normal Debounce is used. Only if the sensor is activated for a full five minutes will the "car illegally parked" message be transmitted.

TO USE SWITCH 1 AS A NORMAL DEBOUNCED CONTACT CLOSURE:

- Pick up the telephone receiver and listen for the acknowledge tone.
- Select the code for the desired Debounce time from Table 7 below.
- Dial "**812x**", "x" being the selected code from Table 7, below. A beep indicates the command is accepted.

NOTE: For the "No Parking" zone example above, dial "8126" for 5-minute debounce.

- To complete the programming, dial "**999**", wait for the beep, then hang up the telephone.

TO USE SWITCH 2 AS A NORMAL DEBOUNCED CONTACT CLOSURE:

- Pick up the telephone receiver and listen for the acknowledge tone.
- Select the code for the desired Debounce time from Table 2, below.
- Dial "**822x**", "x" being the selected code from Table 7, below. A beep indicates the command is accepted.
- To complete the programming, dial "**999**", wait for the beep, then hang up the telephone.

- 2. HOLDOFF DEBOUNCE** option transmits messages immediately upon change of switch condition, and will also hold off a message of further change for the time period of the selected debounce.

EXAMPLE: A Quick Talk is used as a gate doorbell. It is practical for the message to be transmitted immediately, and also desirable to have a one-minute debounce before the same message is re-sent, even if the button is pushed repeatedly.

TO USE SWITCH 1 AS A NORMAL HOLDOFF CONTACT CLOSURE:

- Pick up the telephone receiver and listen for the acknowledge tone.
- Dial "**5110**" to suppress the phrase for Switch 1 OPEN, and to prevent message transmission for the button being pressed.
- Select the code for the desired Holdoff time from Table 8 below.
- Dial "**813x**", "x" being the selected code from Table 8, below. A beep indicates the command is accepted.

NOTE: For the gate doorbell example above, dial "8134" for 1-minute holdoff.

- To complete the programming, dial "**999**", wait for the beep, then hang up the telephone.

TO USE SWITCH 2 AS A NORMAL HOLDOFF CONTACT CLOSURE:

- Pick up the telephone receiver and listen for the acknowledge tone.
- Dial "**5210**" to suppress the phrase for Switch 2 OPEN, and to prevent message transmission for the button being pressed.
- Select the code for the desired Holdoff time from Table 8 below.
- Dial "**823x**", "x" being the selected code from Table 8, below. A beep indicates the command is accepted.
- To complete the programming, dial "**999**", wait for the beep, then hang up the telephone.

TABLE 7

DEBOUNCE TIME	CODE NUMBER
No Debounce	1
10 seconds	2
30 seconds	3
1 minute	4
3 minutes	5
5 minutes	6 - DEFAULT

TABLE 8

HOLDOFF TIME	CODE NUMBER
No Holdoff	1
10 seconds	2
30 seconds	3
1 minute	4
3 minutes	5
5 minutes	6 - DEFAULT

5. MONITORING 4 - 20 mA SENSOR CURRENT LOOPS W/ ANALOG MODES

TO USE QUICK TALK TO MONITOR 4-20 mA SENSOR CURRENT LOOPS WITH ANALOG INPUT MODES

Quick Talk can act as a current sink after a resistor is connected between the Switch 1 positive and negative terminals. The resistance value is selected to scale the current to the permitted 0 - 5 Voltage range for the Switch 1 input to Quick Talk. See the following formula, and Fig-8.

$$\frac{5 \text{ Volts (max. permitted Voltage)}}{20 \text{ mA (max. current from sensor loop)}} = \frac{250 \text{ Ohms}}{\text{of resistance}}$$

NOTES: Using a lower resistance value with the 4-20 mA current loop produces less than 5 V at the Switch 1 input; since the full 5 Volt range is not used, measurement resolution is reduced.

Using a higher resistance value at 20 mA produces greater than 5V at the Switch 1 input, which risks damaging the Quick Talk unit.

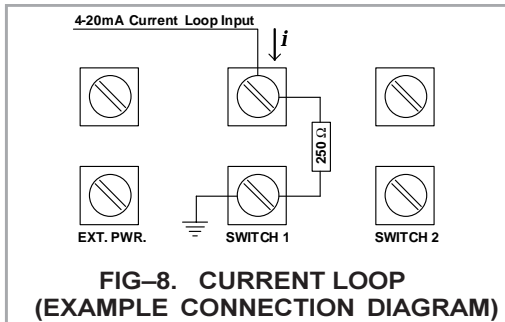

FIG-8. CURRENT LOOP (EXAMPLE CONNECTION DIAGRAM)

6. SOLAR PANELS FOR OPERATING & CHARGING NI-CD BATTERIES

TO USE SOLAR POWER PANELS FOR OPERATION AND FOR CHARGING INTERNAL NI-CD BATTERIES:

Follow the instructions on page 8 for using Ni-Cd batteries, including Step c. to enable the Battery Saver, and d. to minimize the charging current needed. **DO NOT EXCEED 15 Volts at the external battery terminals.**

CALCULATING THE SOLAR PANEL SIZE:

Quick Talk uses little power when it is not transmitting. The estimated *time the unit does transmit* can accurately determine solar panel size requirements to charge Ni-Cd batteries. The following formula sizes the panel properly:

EXAMPLE: Assume the Quick Talk transmits for one minute of every hour, on average (1/60 hour). Further assume the Quick Talk draws 150 mA of current while transmitting (150 mA).

NOTE: 150 mA is a bit higher than real consumption; the panel will be slightly oversized.

The formula to calculate required mA hours:

$$(1/60 \text{ hr.}) \times (150 \text{ mA}) \times \left(\frac{\text{No. of hours}}{\text{day operation/ day}} \right) = \text{Req'd. mA hr./ day}$$

Plug the Example into the Formula:

$$(1/60 \text{ hour}) (150\text{mA}) (24 \text{ hours/ day}) = 60 \text{ mA hours/ day}$$

RESULTS: In this Example, the Quick Talk solar panel supplies 60 mA-hours in a 24-hour period.

NOTE: Study solar panel manufacturers' information.

7. USING LATCHING OPTION

TO USE LATCHING MODE:

Use the Quick Talk latching mode application if repeated transmissions are desired with a momentary switch (i.e.: a push-button). The latching effect maintains message repeats after the momentary switch change has ended.

EXAMPLE: To use a Quick Talk in a paint department, set it to repeat phrase transmissions after the "Press for Help" push-button is activated. In this example, the recorded phrase transmits every 2 minutes until the Quick Talk latch mode resets (an employee resets Switch 2).

TO PROGRAM LATCHING MODE:

NOTE: This example uses a Normally Open switch.

a. Pick up the telephone receiver and listen for the acknowledge tone.

NOTE: To remove possible interference from prior programming, in this application it is best to use a Quick Talk unit set to factory defaults.

To restore factory defaults:

Dial "978" for VHF units; dial "979" for UHF units.

To program a different frequency than the default, refer to page 7.

b. If you have a Normally Open switch, dial "814" to latch the CLOSED condition on Switch 1. A beep indicates the command is accepted.

c. Dial "312". Quick Talk sounds three short tones to prompt you to begin speaking, then record the Switch 1 phrase, to be no longer than eight seconds.

EXAMPLE: Record "Help needed Paint Department."

d. Dial "5110" to suppress the Switch 1 OPEN message (preventing transmitted messages when the sales person resets the unit).

NOTE: Skip Step d. if it is desirable to send a message when the unit is reset.

e. Dial "5124" to select 2 minutes as the message repeat schedule for Switch 1 latched condition; refer to Table 9.

f. Dial "999", wait for the beep, then hang up the telephone to complete the programming.

TABLE 9

TIME BETWEEN MESSAGES	CODE NUMBER
None/ Never	0
On Changes Only	1 - DEFAULT
30 seconds	2
1 minute	3
2 minutes	4
5 minutes	5
10 minutes	6
30 minutes	7
1 hour	8
2 hours	9

SETTING ANALOG MODES (continued from page 17)

- 1. ANALOG INPUT MODE:** Voltages above High Threshold Setpoint cause Switch 1 OPEN message to transmit. Voltages below Low Threshold Setpoint cause Switch 1 CLOSED message to transmit. The dead zone—an area of hysteresis provided by the difference between High and Low Threshold Setpoints—prevents unwanted messages, caused by noise or minor signal changes. See Fig-9.

When the input is in CLOSED condition, a change to OPEN condition occurs only when the signal exceeds the High Threshold Setpoint. Similarly, when the input is in OPEN condition, the change to CLOSED condition occurs only when the signal is less than the Low Threshold Setpoint.

To Set Analog Input Mode:

- Pick up the telephone receiver and listen for the acknowledge tone.
- Dial **"8162"** to set Quick Talk to Analog Input Mode—a beep indicates the command is accepted.
- Dial **"999"**, wait for the beep, then hang up the telephone to complete programming.

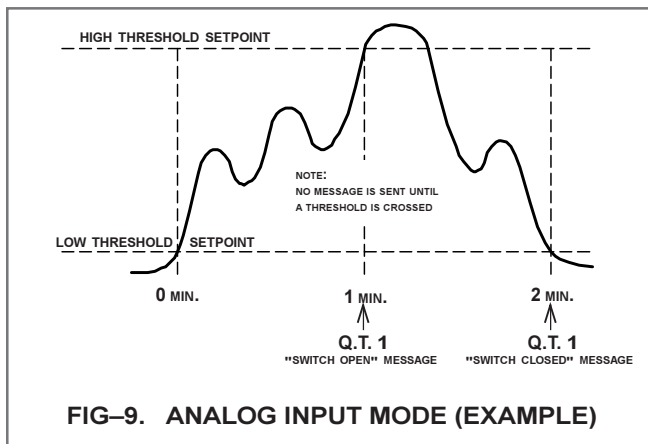

- 2. TERMINATED ALARM INPUT MODE:** This mode is useful in security alarm applications, where the "Secure" (Good) condition is a range of voltages. Voltages above or below this range represent "Alarm" (Bad) conditions. See Fig-10.

The "Secure" condition is the range of voltage between the High and Low Threshold Setpoints. Switch 1 OPEN message is activated in this range. Voltage above High Threshold Setpoint, or below Low Threshold Setpoint activates the Switch 1 CLOSED message.

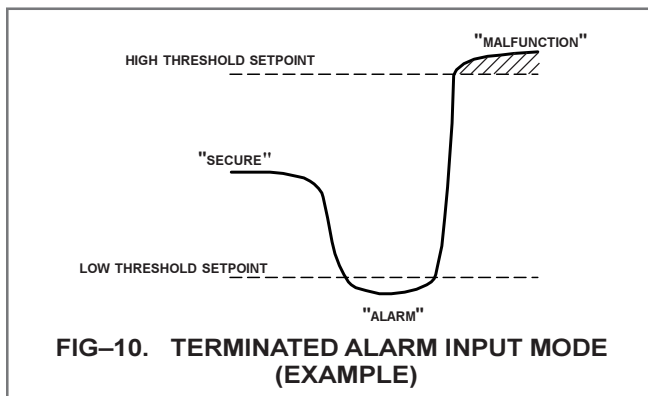

To Set Terminated Alarm input Mode:

- Pick up the telephone receiver and listen for the acknowledge tone.
- Dial **"8163"** to set Quick Talk to Terminated Alarm Input Mode—a beep indicates the command is accepted.
- Dial **"999"**, wait for the beep and then hang up the telephone to complete the programming.

Setting the High Threshold Setpoint in either Analog Input, or in Terminated alarm Input Mode:

- Pick up the telephone receiver and listen for the acknowledge tone.
- Dial **"818xxx"**, "xxx" being the selected code from Table 1, below. A beep indicates the command is accepted.

EXAMPLE: 185 represents a threshold of approximately 3.6 Volts. Dial "818185" to set 3.6 Volts as the High Threshold Setpoint.

- Dial **"999"**, wait for the beep, then hang up the telephone to complete the programming.

Setting the Low Threshold Setpoint in either Analog Input, or in Terminated alarm Input Mode:

- Pick up the telephone receiver and listen for the acknowledge tone.
- Dial **"817xxx"**, "xxx" being the selected code from Table 1, below. A beep indicates the command is accepted.

EXAMPLE: 85 represents a threshold of approximately 1.6 Volts. Dial "817085" * to set 1.6 Volts as the Low Threshold Setpoint.

*** NOTE:** Inserting a zero before a 2-digit number (Example: "85"), completes the command. Insert two zeros in front of a one-digit number.

- Dial **"999"**, wait for the beep, then hang up the telephone to complete the programming.

To revert to Contact Closure Mode, using Switch 1 as a Contact Closure Input:

- Pick up the telephone receiver and listen for the acknowledge tone.
- Dial **"8161"**—a beep indicates the command is accepted.
- Dial **"999"**, wait for the beep, then hang up the telephone to complete the programming.

TABLE 10

THRESHOLD VOLTAGE SETTING	CODE NUMBER
0 volts	000
1 volt	051
2 volts	102
3 volts	153
4 volts	204
5 volts	255

8. RECORDING UNIQUE POWER FAILURE MESSAGES

What is the purpose of recording a unique Voice Phrase for the Power Failure Message? When it senses power failure, Quick Talk transmits a factory-programmed "Power Failure" message no more often than once an hour.

If you have several units grouped within radio range of one another, we recommend you customize messages to easily identify the specific unit.

NOTE: Also physically mark the Quick Talk case with the same unique identifier (number) you record for Quick Talk location phrasing (see page 13).

Do I need to program this feature? If you use only one Quick Talk in an area, or if you regularly change Quick Talk batteries, the factory-programmed message may be sufficient: you can skip to the next section.

TO RECORD POWER FAILURE PHRASE:

- a. Pick up the telephone receiver and listen for the acknowledge tone.
- b. Dial "**34**"—Quick Talk prompts you with three short tones to begin speaking.

NOTE: Your recorded POWER FAIL phrase is to be no longer than 1.5 seconds.

EXAMPLE: "*Power fail fivec.* Hang up the telephone when you are done speaking.

- d. To review the POWER FAIL phrase, dial "**44**".
- e. Repeat steps "a" through "d" until you are pleased with the results.

9. ENABLE/ DISABLE STATUS MESSAGES

TO DISABLE LOW BATTERY MESSAGE:

- a. Pick up the telephone receiver and listen for the acknowledge tone.
- b. Dial "**941**".

TO ENABLE LOW BATTERY MESSAGE:

- a. Pick up the telephone receiver and listen for the acknowledge tone.
- b. Dial "**942**".

NOTE: The default is Low Battery Message "On."

TO DISABLE EXTERNAL POWER FAILURE MESSAGE:

- a. Pick up the telephone receiver and listen for the acknowledge tone.
- b. Dial "**951**".

TO ENABLE EXTERNAL POWER FAILURE MESSAGE:

- a. Pick up the telephone receiver and listen for the acknowledge tone.
- b. Dial "**952**".

NOTE: The default is Power Failure Message "Off."

10. SETTING BATTERY SAVER OPTIONS

TO SET BATTERY SAVER OPTIONS:

The Battery Saver factory default is "Battery Saver enabled." In this setting, which greatly extends battery life, Quick Talk checks switch inputs for changes 4 times a second.

- a. Dial "**932**" to enable Battery Saver.

NOTE: DO NOT disable the Battery Saver unless you need to detect very fast changes in the switch inputs.

To detect very fast changes, set Quick Talk to check switch inputs rapidly:

- b. Dial "**931**" to disable Battery Saver.

NOTE: Powering the Quick Talk with an external Power Supply is very practical with the Battery Saver Option disabled, because Quick Talk draws approximately 7 mA continuously with this setting.

QUICK TALK INSTALLATION

WHEN YOU ARE FINISHED PROGRAMMING:

1. **Hang up and disconnect** the telephone from the internal jack on the Quick Talk.
2. **Test the operation** of the Quick Talk before putting it into service by activating the switch and listening to the message(s) received on your radio.
3. **Replace the cover** and (4) cover screws; snug down, but do not overtighten the screws. Excessive force can break the plastic enclosure material.
NOTE: Refer to FIG-7 on the next page.
4. **Attach the antenna and seal the connection:**
 - a. Insert, rotate and lock the antenna to the Quick Talk antenna jack.
 - b. Orient the antenna in a vertical position.
 - c. Seal the antenna connection to hold the antenna in vertical position, to protect antenna fittings, and to maintain water-resistance of the Quick Talk in wet or outdoor environments.

Use Archer Connector Sealant, Radio Shack Catalog Number 278-1645 or an equivalent. Wrap the connection with the sealant tape and press it securely in place. See FIG-7 and instructions for the sealant.

5. **Test for sufficient broadcast range** when choosing the location. For maximum range and coverage, install the unit as high off the ground as possible. Be aware that metal or wires near the antenna can block or absorb radio transmissions. Choose a well-shaded location.

NOTE: An optional high gain antenna is available from Ritron; call for information.

6. **Position the unit** as shown in FIG-7, and secure it in place with screws through the enclosure flanges. Do not overtighten these screws; you might break the plastic flanges.

IMPORTANT: Contact a qualified technician or electrician if you are not certain your installation will work properly and safely.

CARE AND MAINTENANCE

Moisture: When the antenna sealant and power cable recommendations are followed, the Quick Talk is highly weather-resistant in outdoor environments. Do not immerse the unit in water.

Temperature: The Quick Talk is designed to operate between -22 and +140 degrees Fahrenheit. Like all electronic equipment, Quick Talk should not be subjected to extreme heat. A shaded area is an ideal outdoor location.

Vibrations/ Shocks: Though the Quick Talk is designed to be rugged, it cannot be expected to survive extreme abuse.

Chemicals: Do not use harsh, corrosive or abrasive chemicals to clean the Quick Talk case; use only a cloth moistened with water. Do not attempt to clean the printed circuit board inside the housing.

Batteries: Use only fresh, new alkaline batteries when programming Quick Talk. Acceptable brands and types are: Duracell MX1500B, Eveready E91, Rayovac 815 or equivalent.

NOTE: Refer to the Advanced Features Owner's Manual for information on using rechargeable NiCad AA batteries, charged by an optional external 12 Volt DC power supply.

Estimated Battery Life: Starting with a fresh set of AA alkaline batteries, Quick Talk can transmit about 7,000 voice messages over a period of one year before the batteries will need to be replaced.

Automatic Low Battery Alert Message: If the battery voltage drops below approximately 6 Volts, the Quick Talk transmits a factory prerecorded message, "Low Battery", every 60 minutes. When this occurs, replace the batteries promptly — within a day or so.

FIG 7: QUICK TALK INSTALLATION

* **WARNING:** The antenna connection **MUST BE SEALED** if the Quick Talk is to be used outdoors. See the illustration, and Step 4 on previous page.

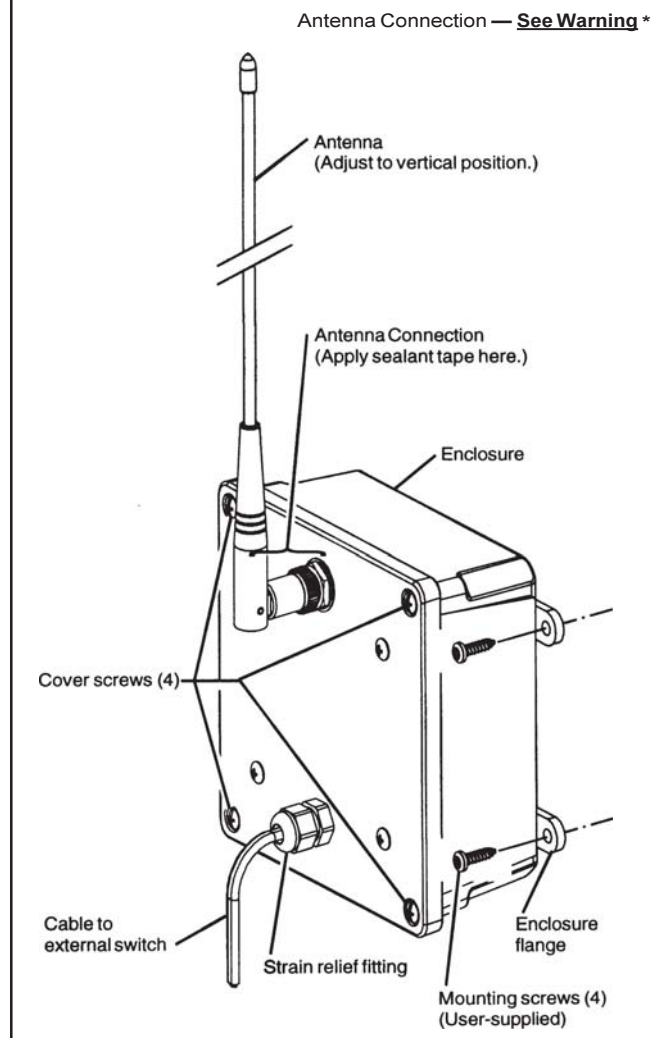

— QUICK REFERENCE GUIDE —

DIAL CODE DESCRIPTION

FREQUENCY PROGRAMMING

- 1-1 TX Freq. 2 digit code: Table 1 (See page 6.)
- 1-2 TX Freq., 6 digit: Dealer programming ONLY; enter 1st 6 digits of frequency.

SUB-AUDIBLE CODED SQUELCH PROGRAMMING

- 2-1 CTCSS/ QC® 2-digit code: Table 2 (See page 7.)
- 2-2 DCS/ DQC™ 3 digit code: Table 3 (See page 8.)

RECORDING VOICE PHRASES

- 3-1-1 Record "Switch 1 Open" Phrase
- 3-1-2 Record "Switch 1 Closed" Phrase
- 3-2-1 Record "Switch 2 Open" Phrase
- 3-2-2 Record "Switch 2 Closed" Phrase
- 3-3 Record Location Phrase
- 3-4 Record Power Failure Phrase
- 3-5 Record Low Battery Phrase

PLAY BACK PHRASES

- 4-1-1 Play Switch 1 OPEN Condition Phrase
- 4-1-2 Play Switch 1 CLOSED Condition Phrase
- 4-2-1 Play Switch 2 OPEN Condition Phrase
- 4-2-2 Play Switch 2 CLOSED Condition Phrase
- 4-3 Play Location Phrase
- 4-4 Play Power Fail Phrase
- 4-5 Play Low Battery Phrase

TIME BETWEEN MESSAGES:

SWITCH 1 OPEN

- 5-1-1-0 Suppressed messages
- 5-1-1-1 On changes only — DEFAULT
- 5-1-1-2 30 seconds
- 5-1-1-3 1 minute
- 5-1-1-4 2 minutes
- 5-1-1-5 5 minutes
- 5-1-1-6 10 minutes
- 5-1-1-7 30 minutes
- 5-1-1-8 1 hour
- 5-1-1-9 2 hours

SWITCH 1 CLOSED

- 5-1-2-0 Suppressed messages
- 5-1-2-1 On changes only — DEFAULT
- 5-1-2-2 30 seconds
- 5-1-2-3 1 minute
- 5-1-2-4 2 minutes
- 5-1-2-5 5 minutes
- 5-1-2-6 10 minutes
- 5-1-2-7 30 minutes
- 5-1-2-8 1 hour
- 5-1-2-9 2 hours

SWITCH 2 OPEN

- 5-2-1-0 Suppressed messages
- 5-2-1-1 On changes only — DEFAULT
- 5-2-1-2 30 seconds
- 5-2-1-3 1 minute
- 5-2-1-4 2 minutes
- 5-2-1-5 5 minutes
- 5-2-1-6 10 minutes
- 5-2-1-7 30 minutes
- 5-2-1-8 1 hour
- 5-2-1-9 2 hours

DIAL CODE DESCRIPTION

TIME BETWEEN MESSAGES: (continued)

SWITCH 2 CLOSED

- 5-2-2-0 Suppressed messages
- 5-2-2-1 On changes only — DEFAULT
- 5-2-2-2 30 seconds
- 5-2-2-3 1 minute
- 5-2-2-4 2 minutes
- 5-2-2-5 5 minutes
- 5-2-2-6 10 minutes
- 5-2-2-7 30 minutes
- 5-2-2-8 1 hour
- 5-2-2-9 2 hours

SCHEDULED MESSAGE REPEAT LIMIT:

SWITCH 1 OPEN

- 6-1-1-1 One time
- 6-1-1-2 Two times
- 6-1-1-3 Three times
- 6-1-1-4 Four times
- 6-1-1-5 Five times
- 6-1-1-6 Six times
- 6-1-1-7 Seven times
- 6-1-1-8 Eight times
- 6-1-1-9 Repeat forever — DEFAULT

NOTE: If Time Between Messages (above), is changed from default "On Changes Only," message is repeated by active Repeat Schedule.

SWITCH 1 CLOSED

- 6-1-2-1 One time
- 6-1-2-2 Two times
- 6-1-2-3 Three times
- 6-1-2-4 Four times
- 6-1-2-5 Five times
- 6-1-2-6 Six times
- 6-1-2-7 Seven times
- 6-1-2-8 Eight times
- 6-1-2-9 Repeat forever — DEFAULT

SWITCH 2 OPEN

- 6-2-1-1 One time
- 6-2-1-2 Two times
- 6-2-1-3 Three times
- 6-2-1-4 Four times
- 6-2-1-5 Five times
- 6-2-1-6 Six times
- 6-2-1-7 Seven times
- 6-2-1-8 Eight times
- 6-2-1-9 Repeat forever — DEFAULT

SWITCH 2 CLOSED

- 6-2-2-1 One time
- 6-2-2-2 Two times
- 6-2-2-3 Three times
- 6-2-2-4 Four times
- 6-2-2-5 Five times
- 6-2-2-6 Six times
- 6-2-2-7 Seven times
- 6-2-2-8 Eight times
- 6-2-2-9 Repeat forever — DEFAULT

PHRASE REPEATS IN EACH MESSAGE:

SWITCH 1 OPEN

- 7-1-1-1 One time — DEFAULT
- 7-1-1-2 Two times
- 7-1-1-3 Three times
- 7-1-1-4 Four times
- 7-1-1-5 Five times
- 7-1-1-6 Six times
- 7-1-1-7 Seven times
- 7-1-1-8 Eight times
- 7-1-1-9 Nine times

(Quick Reference Guide, continued from page 24)

DIAL CODE DESCRIPTION

PHRASE REPEATS IN EACH MESSAGE: (continued)

SWITCH 1 CLOSED

- 7-1-2-1 One time — DEFAULT
- 7-1-2-2 Two times
- 7-1-2-3 Three times
- 7-1-2-4 Four times
- 7-1-2-5 Five times
- 7-1-2-6 Six times
- 7-1-2-7 Seven times
- 7-1-2-8 Eight times
- 7-1-2-9 Nine times

SWITCH 2 OPEN

- 7-2-1-1 One time — DEFAULT
- 7-2-1-2 Two times
- 7-2-1-3 Three times
- 7-2-1-4 Four times
- 7-2-1-5 Five times
- 7-2-1-6 Six times
- 7-2-1-7 Seven times
- 7-2-1-8 Eight times
- 7-2-1-9 Nine times

SWITCH 2 CLOSED

- 7-2-2-1 One time — DEFAULT
- 7-2-2-2 Two times
- 7-2-2-3 Three times
- 7-2-2-4 Four times
- 7-2-2-5 Five times
- 7-2-2-6 Six times
- 7-2-2-7 Seven times
- 7-2-2-8 Eight times
- 7-2-2-9 Nine times

DEBOUNCE OPTIONS

SWITCH 1 MODE—NORMAL

- 8-1-1 Normal On/ Off

SWITCH 1 MODE—DEBOUNDED CONTACT

- 8-1-2-1 No contact debounce
- 8-1-2-2 10 seconds of debounce
- 8-1-2-3 30 seconds of debounce
- 8-1-2-4 1 minute of debounce
- 8-1-2-5 3 minutes of debounce
- 8-1-2-6 5 minutes of debounce

SWITCH 1 MODE—HOLDOFF CONTACT

- 8-1-3-1 No contact holdoff
- 8-1-3-2 10 seconds of holdoff
- 8-1-3-3 30 seconds of holdoff
- 8-1-3-4 1 minute of holdoff
- 8-1-3-5 3 minutes of holdoff
- 8-1-3-6 5 minutes of holdoff

SWITCH 2 MODE—NORMAL

- 8-2-1 Normal On/ Off

SWITCH 2 MODE—DEBOUNDED CONTACT

- 8-2-2-1 No contact debounce
- 8-2-2-2 10 seconds of debounce
- 8-2-2-3 30 seconds of debounce
- 8-2-2-4 1 minute of debounce
- 8-2-2-5 3 minutes of debounce
- 8-2-2-6 5 minutes of debounce

SWITCH 2 MODE—HOLDOFF CONTACT

- 8-2-3-1 No contact holdoff
- 8-2-3-2 10 seconds of holdoff
- 8-2-3-3 30 seconds of holdoff
- 8-2-3-4 1 minute of holdoff
- 8-2-3-5 3 minutes of holdoff
- 8-2-3-6 5 minutes of holdoff

DIAL CODE DESCRIPTION

LATCHING OPTIONS

SWITCH 1 MODE—ON/ OFF

- 8-1-4 Latch off — DEFAULT
- 8-1-5 Latch on

SWITCH 1 MODE—INPUT TYPE

- 8-1-6-1 Contact closure — DEFAULT
- 8-1-6-2 Analog Input
- 8-1-6-3 Terminated Alarm Input

SWITCH 1 MODE—LOW THRESHOLD SETPOINT

- 8-1-7-x-x-x 0-0-0 = 0 volt
- 0-5-1 = 1 volt
- 0-8-4 = 1.68 volts — DEFAULT
- 1-0-2 = 2 volts
- 1-5-3 = 3 volts
- 2-0-4 = 4 volts
- 2-5-5 = 5 volts

SWITCH 1 MODE—HIGH THRESHOLD SETPOINT

- 8-1-8-x-x-x 0-0-0 = 0 volt
- 0-5-1 = 1 volt
- 1-0-2 = 2 volts
- 1-5-3 = 3 volts
- 1-7-1 = 3.42 volts — DEFAULT
- 2-0-4 = 4 volts
- 2-5-5 = 5 volts

**NOTE:
For
Switch 1
ONLY**

SPECIAL FEATURES:

CONFIGURATION

- 9-1-1 Configure to One Contact Input — DEFAULT
- 9-1-2 Configure to Two Contact Inputs

ALERT BEEPS

- 9-2-1 One beep — DEFAULT
- 9-2-2 Two beeps
- 9-2-3 Three beeps
- 9-2-4 No beeps

BATTERY SAVER

- 9-3-1 Off
- 9-3-2 On — DEFAULT

LOW BATTERY MESSAGE

- 9-4-1 Off
- 9-4-2 On — DEFAULT
- 9-4-3 Alkaline batteries — DEFAULT
- 9-4-4 Ni-Cd batteries

**IMPORTANT:
See J103
settings,
page 15.**

EXTERNAL POWER MESSAGE

- 9-5-1 Off — DEFAULT
- 9-5-2 On

TRANSMIT DELAY IN 1/32 SECOND INCREMENTS

- 9-6-x-x-x 0-0-0 = No Delay
- 0-2-4 = 3/4 second — DEFAULT
- 0-3-2 = 1 second
- 0-6-4 = 2 seconds
- 0-9-6 = 3 seconds
- 1-2-8 = 4 seconds
- 1-6-0 = 5 seconds
- 1-9-2 = 6 seconds
- 2-2-4 = 7 seconds
- 2-5-5 = 7-31/32 seconds

RESTORE FACTORY DEFAULTS

- 9-7-8 VHF (Frequency = 154.570 MHz)
- 9-7-9 UHF (Frequency = 467.925 MHz)

END TELEPHONE PROGRAMMING

- 9-9-9 End telephone programming & RESTART

Complete Wireless Communication Solutions From The Leader in Workplace 2-Way Radio Systems

Ritron - We Build Wireless Solutions

For nearly 3 decades Ritron has been designing, manufacturing, and supplying reliable, professional wireless communication products for users worldwide. Ritron wireless products will improve the operation, safety, and profitability of any organization by providing instant voice communication between key employees throughout the workplace.



VHF and UHF Display Series Portable Radios

Communicate with multiple workgroups instantly with a push-of-the-button. Rugged and lightweight with built-in weather scan (VHF models only) automatically finds NOAA broadcasts. Other features include Interference Eliminator, Loud and Clear Audio, Removable Quick Swap Battery, and Drop-in Charging Capability.

Accessories

Ritron offers a wide variety of headsets, earsets, remote speaker microphones, multi-unit chargers, and carry holsters to meet all your wireless communication needs.



Liberty™ Extender Repeater Package

A complete on-site two-way communications package that includes the Liberty™ Extender Repeater, Handhelds and Base Station.

The Liberty™ Extender Repeater Package is the perfect solution for: Golf Courses • Schools • Retail Stores • Nursing Homes • Shopping Malls • Special Events • Hospitals • Amusement Parks • Warehouses • Manufacturing Plants • Hotels/Motels • Emergency Operations.

Advantages of Ritron Wireless Products:

- Unique products and features not available from any other source
- Adds speed, flexibility, and responsiveness to any organization
- Fully compatible with virtually any existing two-way radio system
- Designed to work together as a complete system
- No monthly service fees or airtime charges
- Made in the U.S.A.

OutPost™ Radio Callboxes

Battery-operated (6 alkaline "D" cells) callboxes, available in basic or rugged models, provide instant wireless communication over existing two-way radio systems without costly trenching, extensive wiring, or dedicated phone lines.

Ideal for Hotels/Motels • Golf Courses • Schools, Public Parks • Playgrounds • Roadsides • Marinas • Parking Lots or Garages • Receiving or Delivery Docks • Campuses • Shopping Malls • Beachs and Pools • Campgrounds and Hiking Trails • Unattended Gates.

Vandal resistant XT model shown with optional speaker guard

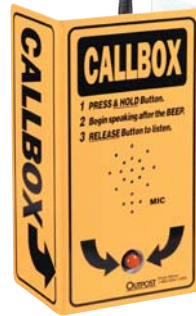

Basic Model

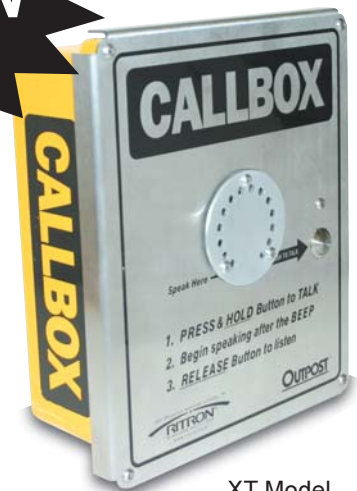

XT Model

Quick Assist™ Wireless Shopper's Callbox

Simple, cost-effective wireless solution for the retailers. This unit provides a fast and easy wireless method for customers to summon a sales associate to a specific department or location without using the PA system. The low-cost Quick Assist II is completely wireless and battery operated. Install it anywhere without costly remodeling. Best of all, it works with virtually any other brand of 2-way radios.

Ideal for use in Fitting Rooms • Locked Cabinet areas • Special Promo areas • Customer Pick-up areas • Seasonal areas • Bulk/Heavy Merchandise areas • Garden/Nursery areas • or anywhere you want to extend "virtual" sales associate coverage.



F.C.C. LICENSING AND REGULATIONS

The Rules and Regulations of the United States Federal Communications Commission (FCC) require you or your radio service provider to have a license for your radio system before activating the Quick Talk radio transmitter. If you already are operating a licensed radio system, you probably can add a Quick Talk without any changes to that license.

The station licensee is responsible for ensuring that transmitter power, frequency and modulation are within the limits specified by the station license, and also for proper operation and maintenance of the radio equipment. These responsibilities include checking the transmitter frequency and modulation periodically, using appropriate methods.

Ritron or your Ritron Dealer can assist you with all these requirements. You may also contact the FCC directly by any of the following methods: To obtain copies of FCC forms and instructions use the FCC Fax-On-Demand system at **202-418-0177**. Request Document 000600.

**For more information, go to the FCC Internet Website at:
www.fcc.gov**

SAFETY STANDARDS — The FCC has adopted a safety standard for human exposure to radio frequency electromagnetic energy emitted by FCC regulated equipment. The Quick Talk conforms to the standards effective at the time of its equipment authorization by the FCC. In general these standards recommend that you:

- DO NOT allow the antenna to come very close to, or to touch exposed parts of the body, especially the face or eyes, while transmitting.
- DO NOT transmit near electrical blasting caps or in an explosive atmosphere.
- DO NOT allow children to play with radio transmitters.
- BE AWARE of the conditions which cause the unit to transmit.

SERVICE - Federal law prohibits you from making any internal adjustments to the transmitter, and from changing transmit frequencies unless you are specifically designated by the licensee.

DO NOT ADJUST OR TAMPER with components or the printed circuit board in any manner not directed in this manual. Unauthorized adjustments may render the unit inoperable; repair will be at owner's expense.

If your radio equipment fails to operate properly, or if you wish to have the Ritron Quick Talk serviced, contact your authorized dealer, or call Ritron at 317-846-1201 and ask for the Repair Department.

RITRON, INC. LIMITED WARRANTY

WHAT THIS WARRANTY COVERS: RITRON, INC. ("RITRON") provides the following warranty against defects in materials and/or workmanship in **RITRON RQT-150 AND RQT-450 QUICK TALK Wireless Voice Alarm Reporter** units under normal use and service during the applicable warranty period, as stated below. "Accessories" means antennas, chargers, wire, cable and items contained in the programming and programming/ service kits.

<u>WHAT IS COVERED</u>	<u>FOR HOW LONG</u>	<u>WHAT RITRON WILL DO</u>
Quick Talk Wireless Voice Alarm Reporter	1 year *	During the first year after date of purchase, RITRON will repair or replace the defective product, at RITRON's option, parts and labor included at no charge.
Accessories	90 days *	* After date of purchase

WHAT THIS WARRANTY DOES NOT COVER:

- Any technical information provided with the covered product or any other products;
- Installation, maintenance or service of the product, unless this is covered by a separate written agreement with RITRON;
- Any products not furnished by RITRON which are attached or used with the covered product, or defects or damage from the use of the covered product with equipment that is not covered;
- Defects or damage, including broken antennas, resulting from:
 - misuse, abuse, improper maintenance, alteration, modification, neglect, accident or act of God, or,
 - the use of covered products other than in normal and customary manner, or,
 - improper testing or installation;
- Defects or damages from unauthorized disassembly, repair or modification, or where unauthorized disassembly, repair or modification prevents inspection and testing necessary to validate warranty claims;
- Defects or damages in which the serial number has been removed, altered or defaced.

IMPORTANT: This warranty sets forth the full extent of RITRON's express responsibilities regarding the covered products, and is given in lieu of all other express warranties. What RITRON has agreed to do above is your sole and exclusive remedy. No person is authorized to make any other warranty to you on behalf of RITRON. Warranties implied by state law, such as implied warranties of merchantability and fitness for a particular purpose, are limited to the duration of this

limited warranty as it applies to the covered product. Incidental and consequential damages are not recoverable under this warranty (this includes loss of use or time, inconvenience, business interruption, commercial loss, lost profits or savings). Some states do not allow the exclusion or limitation of incidental or consequential damages, or limitation on how long an implied warranty lasts, so the above limitations or exclusions may not apply to you. Because each covered product system is unique, RITRON disclaims liability for range, coverage, or operation of the system as a whole under this warranty.

WHO IS COVERED BY THIS WARRANTY: This warranty is given only to the purchaser or lessee of covered products when acquired for use, not resale. This warranty is not assignable or transferable.

HOW TO GET WARRANTY SERVICE: To receive warranty service, you must deliver or send the defective product, delivery costs and insurance prepaid, within the applicable warranty period, to RITRON, INC., 505 West Carmel Drive, Carmel, Indiana 46032, Attention: Warranty Department. Please point out the nature of the defect in as much detail as you can. You must retain your sales or lease receipt (or other written evidence of the date of purchase) and deliver it along with the product. If RITRON chooses to repair or replace a defective product, RITRON may replace the product or any part or component with reconditioned product, parts or components. Replacements are covered for the balance of the original applicable warranty period. All replaced covered products, parts or components become RITRON's property.

RIGHTS TO SOFTWARE RETAINED: Title and all rights or licenses to patents, copyrights, trademarks and trade secrets in any RITRON software contained in covered products are and shall remain in RITRON. RITRON nevertheless grants you a limited non-exclusive, transferable right to use the RITRON software only in conjunction with covered products. No other license or right to the RITRON software is granted or permitted.

YOUR RIGHTS UNDER STATE LAW: This warranty gives you specific legal rights, and you may also have other rights which vary from state to state.

WHERE THIS WARRANTY IS VALID: This warranty is valid only within the United States, the District of Columbia and Puerto Rico.

Go Beyond Normal Limits...SM



RQT-150/ RQT-450 Quick Talk *Wireless Voice Notification Radios*

WARRANTY REGISTRATION/ FIELD FEEDBACK

FAX the completed form to RITRON at 800-251-R-FAX (800-251-7329), or (local FAX) to 317-846-4978, OR mail it as pre-addressed on the back.

Company Name _____ Contact Name _____

Street Address _____

City _____ State _____ Zip _____

Phone Number _____ - _____ - _____ Model Number _____

FAX Number _____ - _____ - _____ Serial Number(s) _____

_____, _____, _____, _____, _____

E-mail _____ Date of Purchase _____

Dealer _____ Purchase Price _____

Please tell us how the Quick Talk solved your problem. _____

My Quick Talk is connected to the following type of switch or sensor — please describe. _____

Please indicate your industry:

- Construction
- Electrical Contractor
- Sound/ Security
- Manufacturing
- Farming/ Ranching
- Wire/ Cable Contractor
- Nursery
- Warehouse
- School
- Lodging/ Hotel
- Apartment/ Condo. Mgmt.
- Other: Specify _____
- Retail Operation
- Hardware

Is this your first purchase of a RITRON product? YES NO

How many Portables/ Mobiles/ Base stations are used in your system? / /
(P) (M) (B)

How did you learn about Ritron products? Ritron Ad Dealer Sales Call
(Please mark all that apply.) Dealer Ad Catalog
 Referral _____
(Please specify.)

What influenced your purchase? Price Size Features
(Please mark all that apply.) Other _____
(Please specify.)



P.O. Box 1998, Carmel, IN 46082-1998 • 505 W. Carmel Dr., Carmel, IN 46032 • USA
Ph: 317-846-1201; 800-USA-1-USA (800-872-1-872) • Fax: 317-846-4978
E-mail: ritron@ritron.com
www.ritron.com



Place
stamp
here.

Tape
here.

Tape
here.

Go Beyond Normal Limits...SM



Attn: Warranty Registration/ Quick Talk™
P.O. Box 1998
Carmel, IN 46082-1998

*Fold along dotted lines, seal with tape, and apply proper postage to mail your Warranty Registration;
OR, you can FAX this form to **RITRON** at 800-251-R-FAX (800-251-7329), or local FAX to 317-846-4978.*

Please send RITRON® Product Literature on:

- JOBCOM® Handheld Radios
- PATRIOT® Handheld Radios
- RITRON® Mobile Radios
- RITRON® Repeater Systems
- RITRON® Trunking Radio Systems

