



**COMPACT
ULTRA-SMALL
PROFESSIONAL TWO-WAY RADIOS**

- One channel
- 1.5 Watts of power
- Quick-change battery
- Drop-in charge capable
- Easy-to-hear, high audio output

MADE IN THE
USA

**RITRON *HANDHELD RADIO*
*OWNER'S MANUAL***

JMX-102

TABLE OF CONTENTS

<u>DESCRIPTION</u>	<u>PAGE</u>
ACCESSORIES	
Optional Accessories	RIGHT
FCC LICENSE REQUIRED	1
FCC Regulations	1
Service	1
How to Obtain an FCC Radio License	1
INTRODUCTION	2
General	2
Model Identification	2
Features	2
!! CAUTIONS !! — ALL RADIOS —	2
BELT CLIP	3
FIG-1: Belt Clip Installation	3
CONTROL & OPERATION	3
FIG-2: Operating Controls	3
BATTERIES	
FIG-3: Battery Access and Installation	4
Optional Charging Accessories	4
General	5
Battery Maintenance and Conditioning	5
LIMITED WARRANTY	BACK COVER
FIGURES:	
1. Belt Clip Installation	3
2. Operating Controls	3
3. Battery Access and Installation	4

ACCESSORIES

OPTIONAL ACCESSORIES:

- BPJS-6N** Spare/Replacement JMX Battery
- AFS-150** 6" Molded Flex Antenna
- AFS-150-S** 3" Molded Flex Antenna
- RHD-1X** Single Ear Headset
- RHD-4X** Dual Ear Headset
- RHD-5X** Low-profile Earloop w/Boom Mic



RHD-1X



RHD-5X



RHD-4X

- RSM-3X** Remote Speaker Microphone
- BCJS-AD** Drop-in Charger: Overnight

RSM-3X



BCJS-AD

- REP-2** Low Profile Earphone
- CCL-B** Cigarette Lighter Charger
- MHA** Cordura Holster w/quick release
- MH-BLS** Belt Loop, quick release

NOTE: Call RITRON at 1-800-USA-1-USA to order, or for a complete accessory listing.

FCC LICENSE REQUIRED

FCC REGULATIONS

LICENSING —

The FCC requires the owners of the radios to obtain a station license before using them.

The station licensee is responsible for ensuring that transmitter power, frequency and deviation are within the limits specified by the station license. The station licensee is also responsible for proper operation and maintenance of the radio equipment. This includes checking the transmitter frequency and deviation periodically, using appropriate methods.

To get a FCC license for VHF or UHF frequencies, submit FCC application Form 600 as indicated in the block at right. Your Ritron dealer can help you with this process.

SAFETY STANDARDS —

The FCC (with its action in General Docket 79-144, March 13, 1985) has adopted a safety standard for human exposure to radio frequency electromagnetic energy emitted by FCC regulated equipment. Ritron observes these guidelines and recommends that you do also:

- DO NOT hold the radio so that the antenna is very close to or touching exposed parts of the body, especially the face or eyes, while transmitting. Keep the radio vertical, two to three inches away while talking into the front panel.
- DO NOT press the Push-To-Talk except when you intend to transmit.
- DO NOT operate radio equipment near electrical blasting caps or in an explosive atmosphere.
- DO NOT allow children to play with any radio equipment that contains a transmitting device.
- Repair of Ritron products should be performed only by Ritron authorized personnel.

SERVICE

Federal law prohibits you from making any internal adjustments to the transmitter, and/ or from changing transmit frequencies unless you are specifically designated by the licensee. If your radio equipment fails to operate properly, or you wish to have the radio programmed, contact your authorized dealer or Ritron.

RITRON, INC., Repair Department
505 West Carmel Drive
Carmel, IN 46032 USA

Phone: 317-846-1201
FAX: 317-846-4978

HOWTOOBTAINANFCCRADIOLICENSE

Federal Communications Commission (FCC) Licensing Information

Because your Ritron radio operates on Private Land Mobile frequencies, it is subject to the Rules and Regulations of the FCC, which requires all operators of these frequencies to obtain a station license before operating their equipment. Make application for your FCC license on FCC Forms 600 and 159.

*To have forms and instructions faxed to you by the FCC, call the **FCC Fax-On-Demand** system at **202-418-0177** from your fax machine; request Document 000600 & Form 159.*

*To have Document 000600 & Form 159 mailed to you, call the **FCC Forms Hotline** at **800-418-FORM** (800-418-3676)*

*For **help with questions** concerning the license application, contact the FCC at **888-CALL-FCC** (888-225-5322)*

*You must **decide which radio frequency(ies)** you can operate on before filling out your application.*

*For help, call Ritron at **800-USA-1-USA** (800-872-1872)*

INTRODUCTION

GENERAL

The JOBCOM JMX-102 radio is designed for business and industry, equipped for two-way operation on one channel. It may be used with optional accessories.

Each JOBCOM radio is packaged with a flexible antenna, a plug-in battery charger and a recharge-able Ni-Cad battery pack installed. Contact your RITRON dealer for available accessories.

IMPORTANT: Because the battery pack can lose its charge during storage and shipping, fully charge it for ten hours before use.

Since the JOBCOM portable transmits on communications frequencies authorized by the Federal Communications Commission (FCC), you must license your radios before use. See "HOW TO OBTAIN A FCC RADIO LICENSE" section on the next page.

MODEL INFORMATION

JOBCOM radios have one of three specific channels installed — see the listing below. A "color dot" label on the case bottom indicates the operating channel (frequency) of the radio. Only units using the same operating channel can communicate with each other.

151.625 MHz (RED dot)
154.570 MHz (BLUE dot)
154.600 MHz (GREEN dot)

LOCAL / DISTANT SQUELCH

The receiver in your JMX-102 radio is capable of two squelch modes, "local" and "distant." Select the appropriate squelch mode for your application, as described in the next column.

IN THE "LOCAL" MODE, sensitivity of the receiver is reduced to "hear" only nearby transmissions; you will not receive weak or distant signals. Use this mode when your talk group members are close together, or to eliminate interference from distant co-channel users.

IN THE "DISTANT" MODE, the receiver is more sensitive to allow reception of weak or distant transmissions. Use this mode when your talk group covers greater range.

NOTE: Squelch is always in the default "distant" mode when you turn your radio ON.

TO CHANGE SQUELCH MODES, simultaneously press both volume buttons (ON/ VOLUME UP and VOLUME DOWN/ OFF). The radio speaker emits a single beep if squelch is in "local" mode. Press both volume buttons a second time; a double beep indicates squelch is in "distant" mode.

This low-cost radio is NOT designed to accept coded signalling modules such as the RITRON Quiet Call™ feature. Call RITRON at 1-800-USA-1-USA for information on other JOBCOM radio models.

TRANSMITTER TIME-OUT

A transmitter time-out feature conserves battery power: if you hold down the PTT continuously for 60 seconds or more, the radio emits a low-pitched tone, then a higher tone, and the transmitter shuts OFF; the radio automatically switches to receive mode.

SQUELCH DISABLE

Press and hold both volume buttons until the speaker emits rapid, continuous beeping. When you release the buttons and hear a rush of noise, squelch is disabled.

Press both volume buttons simultaneously to revert to "local" or "distant" squelch mode.

RECHARGE BATTERY ALERT

When the battery drops below the required charge, the radio emits a long, low tone and turns itself OFF. If you turn it back ON, the radio will beep and shut itself OFF again. Recharging instructions are on the following page.

!! CAUTIONS !!

— ALL RADIOS —

OPERATING PRECAUTIONS

TAKE PRECAUTIONS IN THE FOLLOWING ENVIRONMENTS TO MAXIMIZE THE LIFE OF YOUR ELECTRONIC RADIO EQUIPMENT.

MOISTURE:

JOBCOM radios are not waterproof; DO NOT directly expose them to rain or excessive moisture.

EXTREME HEAT:

High temperatures can damage the battery and other components. DO NOT expose the units to extreme heat or leave them in direct sunlight.

LOW TEMPERATURES:

The capacity of the Ni-Cad battery is greatly reduced in extreme cold. When using the unit in very cold environments, periodically warm the radio beneath your coat.

EXCESSIVE TRANSMISSIONS:

Maximum drain on battery power occurs when you are transmitting. DO NOT hold the Push-To-Talk switch down longer than necessary during transmission intervals.

DO NOT reduce battery service life by attempting to power a radio with a depleted battery; always charge batteries overnight after each day of use.

VIBRATIONS/SHOCKS:

Although your JOBCOM radio is designed to be rugged, it will not survive excessive abuse. Avoid dropping the radio.

NOTE: The optional MH-A holster adds protection against shocks and adverse weather.

BELT CLIP

To attach the belt clip to the radio—

Place the clip on the back of the radio case, aligning the screw hole in the clip with the hole in the case. Tighten the screw. See FIG-1 below.

CAUTION: Use only the included Phillips head screw; a longer screw could damage radio electronics.

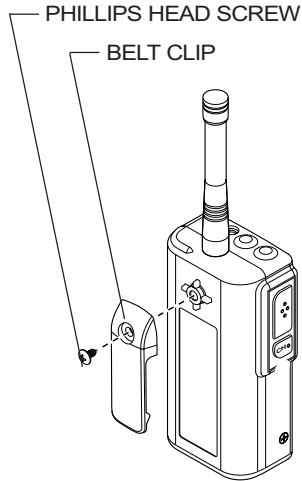
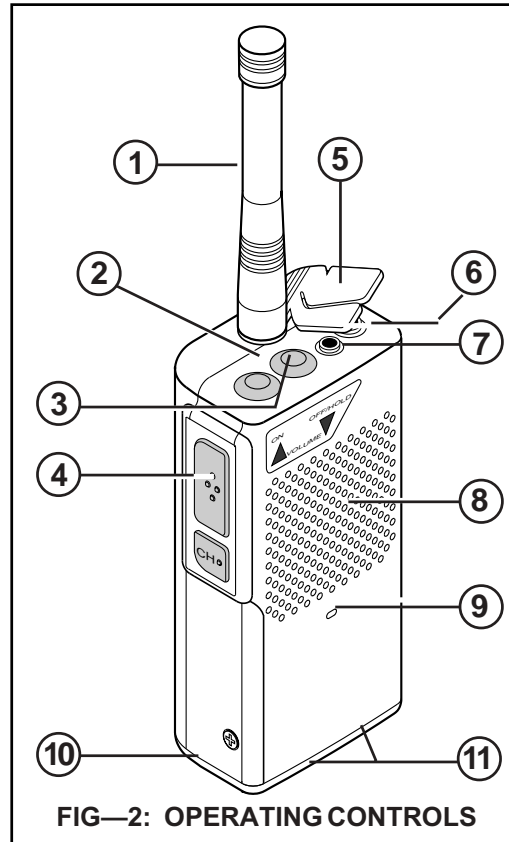

FIG-1: BELTCLIPINSTALLATION

CONTROL & OPERATION



IMPORTANT: Charge the battery pack before using the radio for the first time. Refer to BATTERIES, page 5.

1 ANTENNA

A VHF antenna is packaged with the radio; use only this type of antenna with your unit. Screw the antenna base all the way in the threaded bushing on top of the radio.

The location of the radio affects its range. Moving a few feet in one direction often improves your receiving and transmitting.

2 ON/ VOLUME UP

To switch the unit ON, press the ON/VOLUME UP button; the speaker will emit a brief confirmation tone. Once the radio is ON, press the button to increase volume.

3 VOLUME DOWN/ OFF

Press the VOLUME DOWN/OFF button to decrease volume. To switch OFF the unit, press and hold the button until the speaker emits a double beep.

4 PUSH-TO-TALK SWITCH

Press and hold down this switch when transmitting, then release it to receive.

5 JACK COVER

Snap the jack cover into the audio and charge jack openings when the jack(s) are not in use to seal out dust and moisture.

6 AUDIO ACCESSORY JACK

The audio jack can be used to connect plug-in earphone REP-2 (option), or in conjunction with the charge jack, to connect remote speaker/microphone RSM-3X (option), or a single- or dual-ear headset.

7 CHARGE JACK

Turn the unit OFF when its battery needs charging. Plug the charger cord into the jack labeled CHG at the top of the radio, then plug the charger cube into a 110 VAC outlet. The green lamp on the charger lights while the battery is charging; it will go OFF only when the radio is unplugged from the charger.

8 SPEAKER

The speaker, located behind the front grille, allows you to hear calls on your channel.

9 MICROPHONE

When transmitting, hold the radio about two inches away and talk into the front grille. Shouting does not improve reception for your listener.

10 BATTERY ACCESS DOOR (CASE BOTTOM)

The battery door may be removed to access the battery pack. Refer to BATTERY ACCESS & INSTALLATION, FIG-3, page 4.

11 DROP-IN CHARGING CAPABILITY

Two contacts in the radio bottom permit charging the battery with an optional drop-in charger. See FIG-3, page 4. Refer to OPTIONAL CHARGING ACCESSORIES, page 4.

BATTERIES

FIG—3: BATTERY ACCESS & INSTALLATION

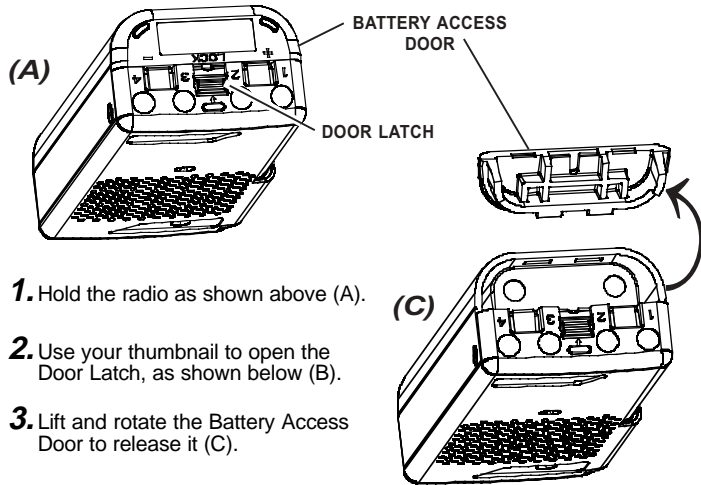

1. Hold the radio as shown above (A).
2. Use your thumbnail to open the Door Latch, as shown below (B).
3. Lift and rotate the Battery Access Door to release it (C).
4. Use the Pull-tab to pull the battery pack out of the case (D).
5. Insert the replacement battery pack, being certain to POSITION IT RELATIVE TO THE CASE AS SHOWN IN (D). Push the Battery Pack in as far as possible.
6. Replace the Battery Access Door. Secure it by closing the Door Latch as shown in (B).
7. Be certain to firmly lock the Door Latch, as shown in (B).

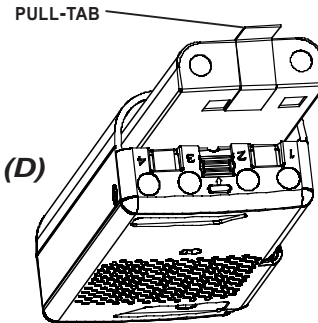
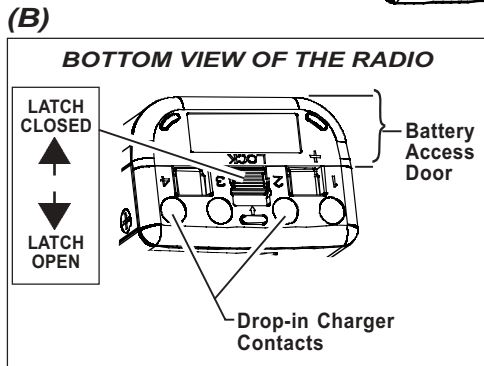

OPTIONAL CHARGING ACCESSORIES

Spare/ Replacement
Battery Pack

Drop-in Battery Charger
with Spacer

JOB COM JMX Accessories:

BPJS-6N

700 mAh Spare Battery Pack

BCJS-AD

Drop-in Charger Adapter

BATTERIES

GENERAL

CAUTION: *Use only RITRON-supplied chargers; using other chargers may cause fire or explosion, or otherwise damage the radio.*

The JMX102 radio is powered by a rechargeable battery pack.

CHARGING

Because the battery pack loses its charge during storage and shipment, fully charge it before first use. To ensure peak radio performance for the next day, charge the battery overnight after each day of use. It charges completely in about ten hours.

TO CHARGE THE BATTERY WITH A RITRON CUBE CHARGER

Plug the charger cord into the charge jack (marked "CHG") on top of the radio. Then plug the cube into an 110 VAC outlet. The green lamp lights while the battery is charging, and should go out only when the cube or cord is unplugged.

TO CHARGE THE BATTERY WITH A RITRON DROP-IN CHARGER

Two charger contacts—visible through the radio case bottom—permit charging the battery with an optional Ritron drop-in charger. The battery pack may be either charged inside the radio case, or removed from the radio case for charging. Each drop-in charger comes with a spacer to permit charging a "spare" battery.

To use the drop-in charger, plug it into a 110 VAC outlet. Set either the radio with the battery installed, or only the battery inside the battery spacer, into the charger. Refer to the illustration in OPTIONAL CHARGING ACCESSORIES, opposite. Each battery contact must rest on a charger contact pin.

NOTE: *Battery pack life averages one year. Follow these guidelines to maximize service life:*

- **CONDITION** battery packs once a month as directed in Battery Maintenance & Conditioning, at right.
- **CONDITION** batteries that are run down. See Battery Maintenance & Conditioning, at right.
- **CHARGE** batteries for 16 hours before storage, and for 16 hours once a month thereafter.
- **DO NOT** overcharge batteries. Unplug the cube charger after 16 hours to avoid overcharging.
- **DO NOT** charge batteries in temperatures colder than about 45°F. Charging batteries in temperatures above 95°F. does not harm them, but can reduce charge capacity.

BATTERY MAINTENANCE & CONDITIONING

Due to the extended run time of the JMX-102 radio, some users may never fully discharge the NiCad battery pack during normal use. Achieve maximum battery life by fully discharging the battery periodically to condition it.

After exposing the battery pack to many cycles of not fully discharging it before recharging, the radio may exhibit reduced battery capacity. This reduced capacity is evident when, after several hours of use, battery voltage drops while the radio is transmitting, causing the radio to emit a dead battery warning tone and shut itself off.

Condition battery packs by the following procedure as either a preventive measure, or if you suspect reduced capacity:

TO CONDITION THE BATTERY PACK:

1. • Use your radio throughout a normal work day without charging.
2. • Press and hold the On/ Volume Up and Volume Down/ Off buttons simultaneously for 8 seconds to place the radio in "open squelch" mode.
 - Release both buttons when you hear the radio beep rapidly; it will then emit a loud "rushing" noise. Press On/ Volume Up to maximize this noise.
3. • Put the radio away in a secure place (possibly a desk drawer), where nothing can press against the buttons to accidentally turn it off or cause it to transmit. Allow the radio to run until it shuts off when the battery is completely discharged. A typical battery pack may require about 8 hours to completely discharge.
4. • When the radio has shut off, charge it overnight for 12-14 hours. The battery will be ready for use with renewed capacity.

NOTE: **A new battery must be charged and discharged several times before it can reach its maximum charge capacity.**

RITRON, INC. LIMITED WARRANTY

WHAT THIS WARRANTY COVERS:

RITRON, INC. ("RITRON") provides the following warranty against defects in materials and/or workmanship in **Ritron JOBCOM Radios, Rechargeable Batteries and Accessories** under normal use and service during the applicable warranty period, as stated below. "Accessories" means antennas, chargers, headsets, earphones, speakers, holsters and microphones. Rechargeable batteries will be replaced during the applicable warranty period only if leakage occurs or the batteries drop below 75% of rated capacity.

<u>WHAT IS COVERED</u>	<u>FOR HOW LONG</u>	<u>WHAT RITRON WILL DO</u>
RITRON JOBCOM Radios	1 year*	During the first year after date of purchase, RITRON will repair or replace the defective product, at RITRON's option, parts and labor included at no charge to you.
RITRON Rechargeable Batteries	1 year*	RITRON will replace the defective battery
RITRON Accessories	90 days*	* After date of purchase

WHAT THIS WARRANTY DOES NOT COVER:

- Any technical information provided with the covered product or any other RITRON products;
- Installation, maintenance or service of the product, unless this is covered by a separate written agreement with RITRON;
- Any products not furnished by RITRON which are attached or used with the covered product, or defects or damage from the use of the covered product with equipment that is not covered, such as defects or damage from the charging or use of batteries other than with covered product;
- Defects or damage, including broken antennas, resulting from:
 - misuse, abuse, improper maintenance, alteration, modification, neglect, accident or act of God,
 - the use of covered products other than in normal and customary manner or,
 - improper testing or installation;
- Defects or damages from unauthorized disassembly, repair or modification, or where unauthorized disassembly, repair or modification prevents inspection and testing necessary to validate warranty claims;

- Defects or damages in which the serial number has been removed, altered or defaced.
- Batteries if any of the seals are not intact.

IMPORTANT: This warranty sets forth the full extent of RITRON's express responsibilities regarding the covered products, and is given in lieu of all other express warranties. What RITRON has agreed to do above is your sole and exclusive remedy. No person is authorized to make any other warranty to you on behalf of RITRON. Warranties implied by state law, such as implied warranties of merchantability and fitness for a particular purpose, are limited to the duration of this limited warranty as it applies to the covered product. Incidental and consequential damages are not recoverable under this warranty (this includes loss of use or time, inconvenience, business interruption, commercial loss, lost profits or savings). **Some states do not allow the exclusion or limitation of incidental or consequential damages, or limitation on how long an implied warranty lasts, so the above limitations or exclusions may not apply to you. Because each covered product system is unique, RITRON disclaims liability for range, coverage, or operation of the system as a whole under this warranty.**

WHO IS COVERED BY THIS WARRANTY

This warranty is given only to the purchaser or lessee of covered products when acquired for use, not resale. This warranty is not assignable or transferable.

HOW TO GET WARRANTY SERVICE

To receive warranty service, you **MUST** deliver or send the defective product, delivery costs and insurance prepaid, within the applicable warranty period, to RITRON, INC., 505 West Carmel Drive, Carmel, Indiana 46032, Attention: Warranty Department.

Please point out the nature of the defect in as much detail as you can. **You MUST retain your sales or lease receipt (or other written evidence of the date of purchase), and deliver it along with the product.** If RITRON chooses to repair or replace a defective product, RITRON may replace the product or any part or component with reconditioned product, parts or components. Replacements are covered for the balance of the original applicable warranty period. All replaced covered products, parts or components become RITRON's property.

RIGHTS TO SOFTWARE RETAINED

Title and all rights or licenses to patents, copyrights, trademarks and trade secrets in any RITRON software contained in covered products are and shall remain in RITRON. RITRON nevertheless grants you a limited non-exclusive, transferable right to use the RITRON software only in conjunction with covered products. No other license or right to the RITRON software is granted or permitted.

YOUR RIGHTS UNDER STATE LAW

This warranty gives you specific legal rights, and you may also have other rights which vary from state to state.

PUB. 14500011 REV. A 07-99

COPYRIGHT© 1999 RITRON, INC. • ALL RIGHTS RESERVED
RITRON® and JOBCOM® ARE REGISTERED TRADEMARKS OF RITRON, INC.